

# 2020 CATALOG

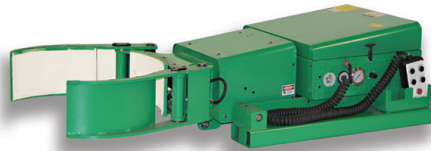

## MATERIAL HANDLING & STORAGE





## Valley Craft Industries, Inc.

In 1953, local beer distributor Carl Weinmann suffered a back injury when he lost control of a loaded hand truck delivering a keg of beer down a flight of stairs. Thinking there had to be a better way, Carl developed the first ever brake system for a hand truck, and Valley Craft Industries was born.

The company has been in Lake City, Minnesota since its founding. Over the last 65 years, Valley Craft has focused on developing safer and more efficient ways to move and store all types of material in industrial and commercial settings.

Today, Valley Craft's line includes a wide variety of mechanical and hydraulic material handling devices and storage solutions including:

- Industry leading Drum Lifts and Positioners
- Professional Grade Hand Trucks
- Box and Drum Dumpers
- Trailers and Carts
- Storage Cabinets and Tool Cabinets
- Lean Manufacturing support equipment

Our Product design team is available to customize any of our standard products to suit your unique requirements or to design a unique purpose-built device from a "Clean Sheet of Paper." We have developed highly customized solutions for a variety of markets including:

- Window and Door Manufacturing
- Automotive Manufacturing
- Food and Beverage Processing
- Roll Handling

Valley Craft products are known for their timeless design and rugged durability. We take great pride that our products are made in America and built to last.

Please visit us at [www.valleycraft.com](http://www.valleycraft.com) to learn more about our solutions and products.

Our Customer Service Specialists will welcome your phone calls at 651-345-3386.

Dennis Campbell  
President and Chief Executive Officer

Interact with us on social media:     

# INDEX

## TABLE OF CONTENTS

### CARTS

A FRAME CARTS .....	4
A FRAME CARTS - HEAVY DUTY .....	5
SECURITY CARTS .....	6
UTILITY CARTS.....	8
CAGE CARTS.....	10

### DRUM LIFTERS

DRUM LIFTERS - HAND POWERED .....	11
DRUM LIFTERS - SEMI-POWERED.....	14
DRUM LIFTERS - FULLY POWERED .....	18

### FORK LIFT ATTACHMENTS

HYDRAULIC.....	22
SKID STEER ATTACHMENT .....	26
MECHANICAL .....	26

### DUMP SYSTEMS

BOX DUMPERS.....	28
CHIP TRUCKS .....	29
DRUM DUMPERS - HYDRAULIC .....	30
DRUM DUMPERS - LEVEL LIFT.....	32
HYDRAULIC SELF DUMPING SYSTEM.....	33

### HAND TRUCKS

CASINO HAND TRUCKS .....	34
CYLINDER HAND TRUCKS .....	35
COMMERCIAL HAND TRUCKS .....	36
DRUM HAND TRUCKS.....	37
HVAC HAND TRUCKS .....	40
INDUSTRIAL HAND TRUCKS.....	40
NURSERY HAND TRUCKS.....	41
PALLET HAND TRUCKS - PALLETS .....	42

### INDUSTRIAL TRAILERS.....

### SHOP EQUIPMENT

INDUSTRIAL DESKS .....	45
BIN WORKBENCH CABINETS.....	46
INDUSTRIAL WORKBENCH CABINETS .....	47
DELUXE WORKBENCH CABINETS .....	48
POST PROTECTORS .....	50
WORK TABLES - ADJUSTABLE HEIGHT .....	51

### STORAGE

SHELVING - HEAVY DUTY .....	52
STORAGE CABINETS - BIN AND SHELF .....	53
STORAGE CABINETS - ELECTRONIC LOCKING ....	55
STORAGE CABINETS - HEAVY DUTY SHELF .....	55
STORAGE CABINETS - 12 GAUGE HEAVY DUTY...56	

# ICON KEY

Please refer to the following icon system to quickly identify the function, power supply, and application of certain products.

## APPLICATION/MATERIAL

 **F** FIBER DRUM - Unit handles most fiber drum styles within defined dimensions.

 **P** PLASTIC DRUM - Unit handles most plastic drum styles within defined dimensions.

 **S** STEEL DRUM - Unit handles most 35, 55, and 85 gal steel drum styles within defined dimensions.

 **C** CYLINDER - Unit handles most round cylinders within defined dimensions.

**Note:** Drum types and style vary in design and quality. We do our best to advise proper usage of our lift attachments and positioners based upon drum type. Therefore we state that “most” of each type of drum are supported. If you have any questions regarding a specific application or drum type, please contact customer service at 651-345-3386.

## POWER SOURCE

 **24V DC** 24 Volt DC - Features a 24-volt DC system, battery indicator gauge, and a keyed On/Off switch. Includes two batteries and 12V AC charger.

 **12V DC** 12 Volt DC - Features a 12volt DC system, Includes two batteries and 12V AC charger.

 **TRUCK POWERED** - Power source comes from the forklift or skid-steer.

 **PNEUMATIC** - Unit function is powered by a pneumatic foot pump system.

 **110V AC** - Unit is powered by plugging into any standard 110 outlet.

 **MANUAL OPERATION** - Unit is powered by a manual crank or other manual method.

## FUNCTION

 **TILT** FORWARD TILT - Unit tilts forward for forward dumping function.

 **360 ROTATE** FULL ROTATION- Unit will rotate 360° both directions.

 **LIFT** LIFT UP & DOWN - Unit will lift products up and down for easy placement.

 **CLAMP** SQUEEZE CLAMP - Unit grips product by clamping on using control panel.

## A-Frame Carts

Valley Craft's A-Frame Carts offer a variety of pegboard and louvered panel combinations for efficient organization of parts and supplies. Highly customizable and great for lean manufacturing and Kaizen events. Heavy duty steel construction with 1,000-lbs. capacity, offered in 36" or 48" lengths. Deck features a 1½" lip with 10" of deck space on each side of the panel. Rolls on two rigid, two swivel 5" phenolic casters. Optional equipment includes bins, floor lock and end panels. Optional end panels create additional storage capacity of up to 25 sq. feet and change the configuration to either a T-Frame or H-Frame. Ships fully assembled.

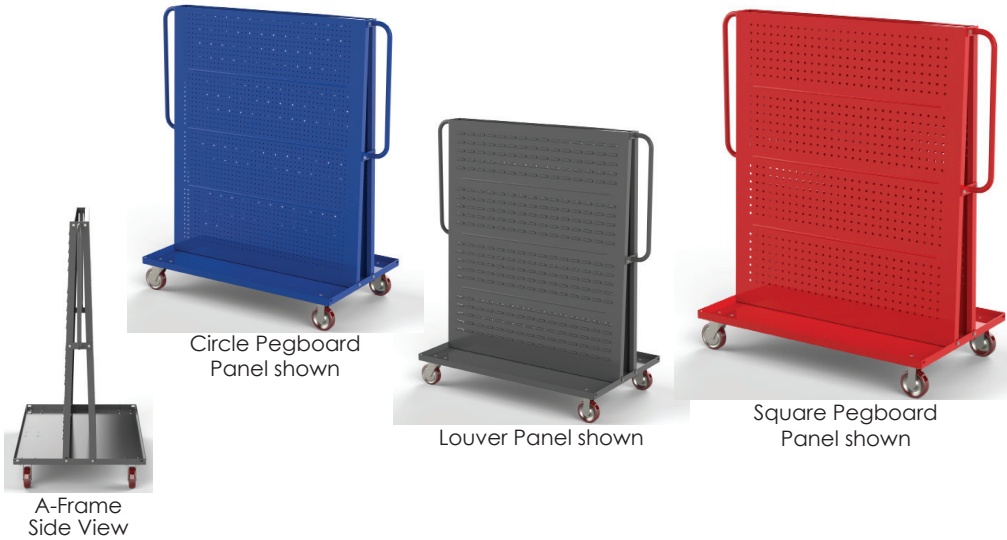

Circle Pegboard Panel shown

Louver Panel shown

Square Pegboard Panel shown

A-Frame Side View

Available Colors:



### A-Frame Base Units

Model Gray	Model Blue	Model Red	Panel Description	Overall Dimensions	Product Weight
F89552	F89552B	F89552R	2 Louver Panels	36" x 30" x 62"	140 lbs
F89551	F89551B	F89551R	1 Louver Panel, 1 Circle Pegboard Panel	36" x 30" x 62"	136 lbs
F89550	F89550B	F89550R	2 Circle Pegboard Panels	36" x 30" x 62"	133 lbs
F89548	F89548B	F89548R	2 Louver Panels	48" x 30" x 62"	170 lbs
F89547	F89547B	F89547R	1 Louver Panel, 1 Circle Pegboard Panel	48" x 30" x 62"	165 lbs
F89546	F89546B	F89546R	2 Circle Pegboard Panels	48" x 30" x 62"	160 lbs

### A-Frame Accessories

Model Gray	Model Blue	Model Red	Description	Overall Dimensions
F89536	F89536B	F89536R	Circle Pegboard End Panel	55" x 30"
F89530			Floor Lock	-
Z80419A7			Extra-Small (XS) Yellow Bins - 24/case	5½" x 4½" x 3"
Z80421A5			Small (S) Yellow Bins - 24/case	7½" x 4½" x 3"
Z80422A4			Medium (M) Yellow Bins - 12/case	11" x 5½" x 5"
Z80424A2			Large (L) Yellow Bins - 12/case	14¾" x 8¼" x 7"
Z80426A0			Extra-Large (XL) Yellow Bins - 6/case	14¾" x 16½" x 7"

# Heavy Duty A-Frame Carts

Heavy Duty A-Frame Carts make storage and delivery of goods and tools safe, effective, and efficient. These single- or double-sided units function as a portable handling system for sorting, storing, and distributing parts and supplies. They are designed to withstand the rigors of industrial environments and constructed of heavy duty steel to provide years of use. Base unit A-Frame does not come with any accessories, which allows you to customize the cart to your specific needs. Choose from a variety of open or closed-front trays, tray dividers, and hanger bars with spindles that will accommodate materials stored on spools. Rolls easily on (2) rigid and (2) swivel 5" casters.

Model	Description	Dimensions	Load Capacity
F81812A5	Single-sided Heavy Duty A-Frame	38" W x 18" D x 63" H	1500 lbs
F81813A4	Single-sided Heavy Duty A-Frame	38" W x 24" D x 63" H	1500 lbs
F81814A3	Double-sided Heavy Duty A-Frame	38" W x 30" D x 63" H	2500 lbs
F81815A2	Double-sided Heavy Duty A-Frame	38" W x 40" D x 63" H	2500 lbs

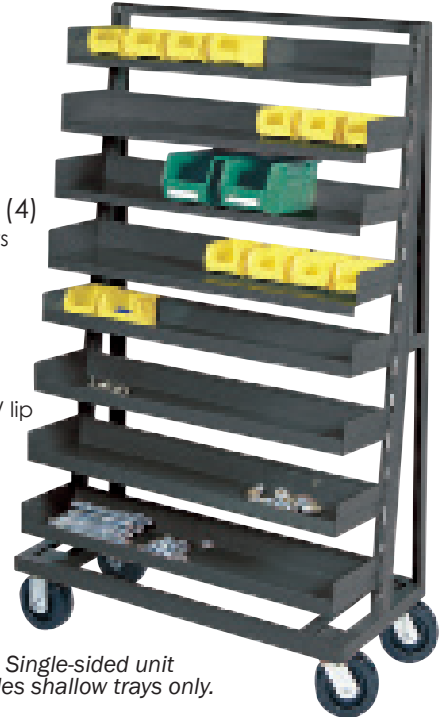

**F81821A2 (10)**  
Spindles



**F81815A2**  
Double Sided A-Frame

**F81820A3 (2)**  
Hanger Bars

**F81818A6 (4)**  
Deep Trays

**F81816A8 (4)**  
Deep Trays with lip

**F81819A5 (4)**  
Shallow Trays

**F81817A7 (4)**  
Shallow Trays w/ lip

**F81813A4**  
Single Sided  
A-Frame

*Note: Single-sided unit handles shallow trays only.*

## Heavy Duty A-Frame Accessories

Model	Description	Dimensions	Product Weight
F81816A8	HD A-Frame Deep Tray with 3" front lip	15" D x 6" H	23 lbs
F81818A6	HD A-Frame Deep Tray with flush front	15" D x 6" H	20 lbs
F81817A7	HD A-Frame Shallow Tray with 3" front lip	9" D x 3" H	13 lbs
F81819A5	HD A-Frame Shallow Tray with flush front	9" D x 3" H	10 lbs
F81820A3	HD A-Frame Hanger Bar	36" W x 4" H	10 lbs
F81821A2	HD A-Frame Spindle	15" Long	1½ lbs
F85825A2	HD A-Frame 9" Tray Divider	9" D x 3" H	1 lb
F85826A1	HD A-Frame 15" Tray Divider	15" D x 6" H	1 lb

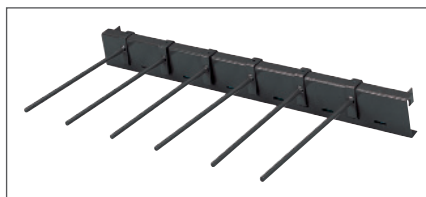

**F81821A2 (6)**  
Spindles

**F81820A3**  
Hanger Bar



**F81816A8**  
Deep Tray  
w/lip



**F81817A7**  
Shallow Tray  
w/lip



**F81818A6**  
Deep Tray



**F81819A5**  
Shallow Tray



**F85826A1**  
15" Tray  
Divider



# Security Carts

Security Carts are constructed of all-welded 2x2" steel wire grid panels to provide total security and see-through visibility. Optional shelves adjust easily along grid panel using plastic shelf clips (four clips included per shelf). 250-lb. capacity shelves are available in 14-gauge steel or 3/4" layered wood. Includes flush-mount locking handle with steel rod locking mechanism. Rolls smoothly on 2 swivel and 2 rigid 8" mold-on rubber casters. Durable powder coat finish available in 3 colors. 2,000-lb capacity. Ships assembled - casters, handle, and shelving require minimal assembly. Other optional accessories available: Metal & Wood Shelves, Pegboard & Louvered Panel inserts, Hitch System for towing, Fork Pockets, and 6th Wheel for pinpoint steering.

Model Gray	Model Blue	Model Red	Description	Dimensions (W x D x H)	Casters	Product Weight
F89557VCGY	F89557VCBL	F89557VCRD	24" Deep Security Cart	48" x 24" x 66"	Four - 8" Mold-On Rubber	257 lbs
F89483VCGY	F89483VCBL	F89483VCRD	30" Deep Security Cart	48" x 30" x 66"	Four - 8" Mold-On Rubber	265 lbs
F89556VCGY	F89556VCBL	F89556VCRD	30" Deep Security Cart	60" x 30" x 66"	Four - 8" Mold-On Rubber	271 lbs

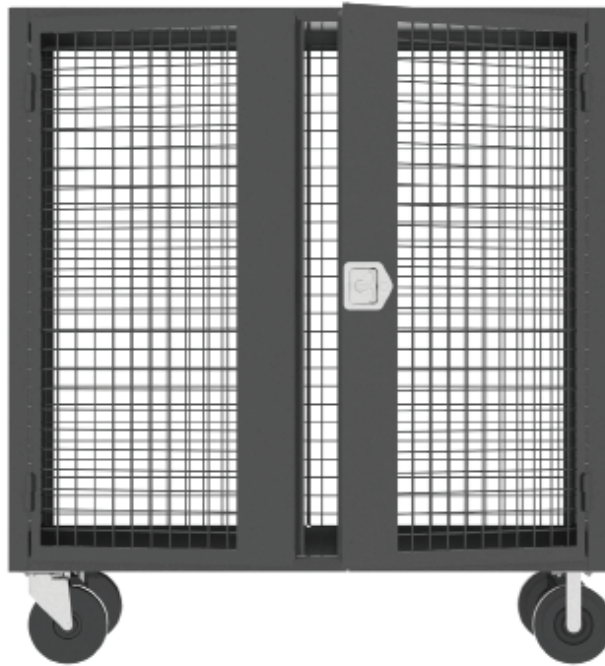

Available Colors:



**F89556VCGY**  
Base Unit Gray

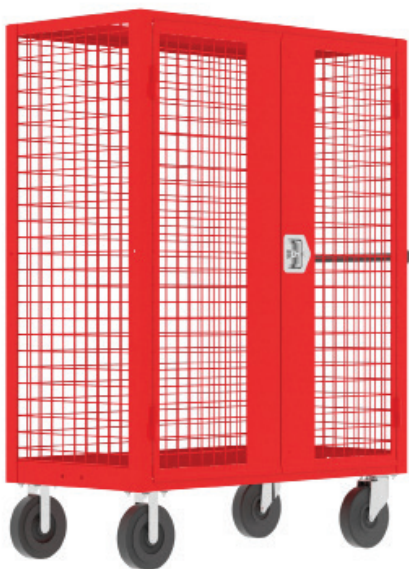

**F89557VCBL**  
Base Unit Blue



**F89557VCRD**  
Base Unit Red

**Security Cart Accessories**

Model Gray	Model Blue	Model Red	Description	Product Weight
F89558	F89558B	F89558R	Fork Pockets (4)	48 lbs
F89560	F89560B	F89560R	Hitch System (tow-bar + hitch)	9 lbs
F89718A4	F89718A1	F89718A3	48" x 24" Metal Shelf	26 lbs
F89719VCGY	F89719VCBL	F89719VCRD	48" x 30" Metal Shelf	34 lbs
F89714A4	F89714A1	F89714A3	60" x 30" Metal Shelf	42 lbs
F89553			24" Removable Handle	2 lbs
F89554			30" Removable Handle	2 lbs



**F89718A4, F89719VCGY, F89714A4**  
Metal Shelf

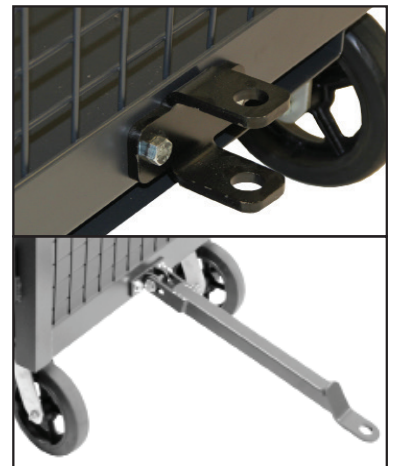

**F89560**  
Hitch System



**F89558**  
Fork Pockets



**F89553 & F89554**  
Removable Handle

# Utility Carts

Valley Craft's line of Utility Carts offer superior balance and control, ideal for both the office and workshop settings. Utility Carts feature all-welded 12 gauge steel construction and an industrial 2000-pound load capacity. Carts are offered with either a flush top or with a 1½" deep edge. Rolls smoothly on either 5" Poly or 8" Molded-On Rubber casters (2 swivel, 2 rigid) and a convenient steel push handle. Durable powder coat finish in gray, blue, or red.

## 2-Shelf Models

- 26" clearance between shelves
- 2,000 lbs load capacity
- 35½" Cart Height with 5" Poly Casters
- 38½" Cart Height with 8" Mold-On Casters

Model Gray	Model Blue	Model Red	Top Shelf Configuration	Cart Dimensions (W X L)	Casters	Product Weight
F89184GYPY	F89184BUPY	F89184RDPY	1½" Lip	18" x 36"	5" Poly	67 lbs
F89184GYMO	F89184BUMO	F89184RDMO			8" Mold-On	76 lbs
F89183GYPY	F89183BUPY	F89183RDPY	Flush	18" x 36"	5" Poly	67 lbs
F89183GYMO	F89183BUMO	F89183RDMO			8" Mold-On	76 lbs
F89226GYPY	F89226BUPY	F89226RDPY	1½" Lip	24" x 36"	5" Poly	81 lbs
F89226GYMO	F89226BUMO	F89226RDMO			8" Mold-On	89 lbs
F89224GYPY	F89224BUPY	F89224RDPY	Flush	24" x 36"	5" Poly	81 lbs
F89224GYMO	F89224BUMO	F89224RDMO			8" Mold-On	89 lbs
F89225GYPY	F89225BUPY	F89225RDPY	1½" Lip	24" x 48"	5" Poly	100 lbs
F89225GYMO	F89225BUMO	F89225RDMO			8" Mold-On	108 lbs
F89223GYPY	F89223BUPY	F89223RDPY	Flush	24" x 48"	5" Poly	100 lbs
F89223GYMO	F89223BUMO	F89223RDMO			8" Mold-On	108 lbs
F89182GYPY	F89182BUPY	F89182RDPY	1½" Lip	30" x 48"	5" Poly	118 lbs
F89182GYMO	F89182BUMO	F89182RDMO			8" Mold-On	127 lbs
F89181GYPY	F89181BUPY	F89181RDPY	Flush	30" x 48"	5" Poly	118 lbs
F89181GYMO	F89181BUMO	F89181RDMO			8" Mold-On	127 lbs
F89180GYPY	F89180BUPY	F89180RDPY	1½" Lip	30" x 60"	5" Poly	141 lbs
F89180GYMO	F89180BUMO	F89180RDMO			8" Mold-On	149 lbs
F89179GYPY	F89179BUPY	F89179RDPY	Flush	30" x 60"	5" Poly	141 lbs
F89179GYMO	F89179BUMO	F89179RDMO			8" Mold-On	149 lbs



**F89223BUMO**  
2-Shelf Cart shown in Blue with 8" Mold-On Casters



**F89226RDPY**  
2-Shelf Cart shown in Red with 5" Poly Casters



### 3-Shelf Models

- 12¼" clearance between shelves
- 2,000 lbs load capacity
- 35½" Cart Height with 5" Poly Casters
- 38½" Cart Height with 8" Mold-On Casters

Model Gray	Model Blue	Model Red	Top Shelf Configuration	Cart Dimensions (W X L)	Casters	Product Weight (lbs)
F89178GYPY	F89178BUPY	F89178RDPY	1½" Lip	18" x 36"	5" Poly	90
F89178GYMO	F89178BUMO	F89178RDMO			8" Mold-On	99
F89177GYPY	F89177BUPY	F89177RDPY	Flush	18" x 36"	5" Poly	90
F89177GYMO	F89177BUMO	F89177RDMO			8" Mold-On	99
F89222GYPY	F89222BUPY	F89222RDPY	1½" Lip	24" x 36"	5" Poly	111
F89222GYMO	F89222BUMO	F89222RDMO			8" Mold-On	120
F89220GYPY	F89220BUPY	F89220RDPY	Flush	24" x 36"	5" Poly	111
F89220GYMO	F89220BUMO	F89220RDMO			8" Mold-On	120
F89221GYPY	F89221BUPY	F89221RDPY	1½" Lip	24" x 48"	5" Poly	139
F89221GYMO	F89221BUMO	F89221RDMO			8" Mold-On	148
F89219GYPY	F89219BUPY	F89219RDPY	Flush	24" x 48"	5" Poly	139
F89219GYMO	F89219BUMO	F89219RDMO			8" Mold-On	148
F89176GYPY	F89176BUPY	F89176RDPY	1½" Lip	30" x 48"	5" Poly	167
F89176GYMO	F89176BUMO	F89176RDMO			8" Mold-On	176
F89175GYPY	F89175BUPY	F89175RDPY	Flush	30" x 48"	5" Poly	167
F89175GYMO	F89175BUMO	F89175RDMO			8" Mold-On	176
F89174GYPY	F89174BUPY	F89174RDPY	1½" Lip	30" x 60"	5" Poly	202
F89174GYMO	F89174BUMO	F89174RDMO			8" Mold-On	211
F89173GYPY	F89173BUPY	F89173RDPY	Flush	30" x 60"	5" Poly	202
F89173GYMO	F89173BUMO	F89173RDMO			8" Mold-On	211

**F89222GYPY**  
3-Shelf Cart shown in gray with 5" Poly Casters



**F89220RDMO**  
3-Shelf Cart shown in Red with 8" Mold-On Casters



### 4-Shelf Models

- 14½" clearance between shelves
- 5" casters - 2 fixed, 2 swivel locking
- 450-lbs shelf capacity (ea) with Mold-On casters (1800 lbs cart total)
- 900-lbs shelf capacity (ea) with Phenolic casters (3600 lbs cart total)

**F89229GYMO**  
4-Shelf Cart shown with Mold-On Rubber Casters



Model Gray	Model Blue	Model Red	Top Shelf Configuration	Cart Dimensions (W X L)	Casters
F89172GYPH	F89172BUPH	F89172RDPH	1½" Lip	24" x 36"	5" Phenolic
F89172GYMO	F89172BUMO	F89172RDMO			5" Mold-On
F89171GYPH	F89171BUPH	F89171RDPH	Flush	24" x 36"	5" Phenolic
F89171GYMO	F89171BUMO	F89171RDMO			5" Mold-On
F89170GYPH	F89170BUPH	F89170RDPH	1½" Lip	24" x 48"	5" Phenolic
F89170GYMO	F89170BUMO	F89170RDMO			5" Mold-On
F89169GYPH	F89169BUPH	F89169RDPH	Flush	24" x 48"	5" Phenolic
F89169GYMO	F89169BUMO	F89169RDMO			5" Mold-On
F89229GYPH	F89229BUPH	F89229RDPH	1½" Lip	30" x 48"	5" Phenolic
F89229GYMO	F89229BUMO	F89229RDMO			5" Mold-On
F89246GYPH	F89246BUPH	F89246RDPH	Flush	30" x 48"	5" Phenolic
F89246GYMO	F89246BUMO	F89246RDMO			5" Mold-On
F89168GYPH	F89168BUPH	F89168RDPH	1½" Lip	30" x 60"	5" Phenolic
F89168GYMO	F89168BUMO	F89168RDMO			5" Mold-On
F89167GYPH	F89167BUPH	F89167RDPH	Flush	30" x 60"	5" Phenolic
F89167GYMO	F89167BUMO	F89167RDMO			5" Mold-On



## Cage Carts

Heavy duty Cage Carts are designed for industrial use and are some of the strongest in the industry. Constructed of durable 2x2" all-welded steel grid panels in 2-, 3-, and 4-sided models. Steel grids can support shelving - some models include one wood shelf and include plastic clips for installation, and other models are available with no shelving. Shelf can be placed anywhere on grid panels and provides a 250-lb shelf capacity. Carts roll smoothly on two swivel, two rigid 8" mold-on rubber casters. A powder coat finish provides added durability for years of use.

### 3-Sided High Profile Models

Model Gray	Model Blue	Model Red	Dimensions (W X L X H)	Includes	Load Cap. (lbs)	Product Wt (lbs)
F89256VCGY	F89256VCBL	F89256VCRD	30" x 57" x 68"	-	1600	160
F89726VCGY	F89726VCBL	F89726VCRD	30" x 57" x 68"	Wood Shelf	1600	180
F89255VCGY	F89255VCBL	F89255VCRD	30" x 45" x 68"	-	1600	140
F89727VCGY	F89727VCBL	F89727VCRD	30" x 45" x 68"	Wood Shelf	1600	155



**F89256VCGY**  
3-Sided Cart in Gray

### 2-Sided High Profile Models

Model Gray	Model Blue	Model Red	Dimensions (W X L X H)	Includes	Load Cap. (lbs)	Product Wt (lbs)
F89254VCGY	F89254VCBL	F89254VCRD	30" x 57" x 68"	-	1600	135
F89729VCGY	F89729VCBL	F89729VCRD	30" x 57" x 68"	Wood Shelf	1600	155



**F89254VCGY**  
2-Sided Cart

### High Profile Cart Accessories

Model	Description	Dimensions (W X L X H)	Includes	Load Cap. (lbs)	Product Wt (lbs)
F89720	Wood Shelf	30" x 57" x 3/4"	Shelf clips	250	20
F89721	Wood Shelf	30" x 45" x 3/4"		250	15

### 3- and 4-Sided Low Profile Models

Model Gray	Model Blue	Model Red	Inside Cart Base Dimensions (W x L)	Outside Cart Dimensions (W X L X H)	No. of Wire Sides	Load Cap. (lbs)	Product Weight (lbs)
F80125VCGY	F80125VCBL	F80125VCRD	24" x 48"	24" x 52" x 37 1/2"	3	2000	91
F80118VCGY	F80118VCBL	F80118VCRD	30" x 60"	30" x 64" x 37 1/2"	3	2000	101
F80126VCGY	F80126VCBL	F80126VCRD	24" x 48"	24" x 52" x 37 1/2"	4	2000	118
F80119VCGY	F80119VCBL	F80119VCRD	30" x 60"	30" x 64" x 37 1/2"	4	2000	131



**F80125VCRD**  
3-Sided Cart in Red

**F80119VCBL**  
4-Sided Cart showing front drop-side folded down



DRIP CATCHING

# Drum Dollies

Drip Catching Drum Dolly is specially designed to be used with an absorbent sock for soaking up liquids from dispensing drums. The oversized dolly helps keep drips in the pan and area around the drum clean. Also eases handling of over-pack drums. Handles drums 22"-28" in diameter. 1,000-lb load capacity.

Model	Description	Load Capacity (lbs)	Product Weight (lbs)
F89709A2	Drum Dolly	1000	30
F89713A6	Dolly w/absorbent collar	1000	32



**F89713A6**  
Drum Dolly with absorbent collar

## Drum Lift

WITH FIXED LEGS - RAPTOR

Ergonomically designed to reduce the risk of injury and allow a single operator to safely handle virtually any kind of drum up to 800 lbs. Glides over standard pallets and picks from containment skids with ease. Hand operated hydraulic pump lifts typical 55-gal. drum 20" off floor. Rolls on 6 x 2" phenolic wheels in front and an 8" rear swivel caster. Single mast design for high visibility. Models available with three different drum handling attachments: beak, strap, or cylinder. Individual attachments are easily interchangeable.



Function			
Part Number	F88575C5	F88577B3	F88576B4
Name	Lift w/ Beak Attachment	Lift w/ Strap Attachment	Lift w/ Cylinder Att
Load Capacity	800 lbs	800 lbs	800 lbs
Weight	232 lbs	259 lbs	240 lbs
Width	50"	50"	50"
Length	40"	40"	40"
Height	62 1/4"	62 1/4"	62 1/4"
Max Height top of drum	54 1/2"	55"	-
Base Elevation 34.5" Drum	20"	20 1/2"	-

**F88575C5**  
Drum Lift with Beak Attachment

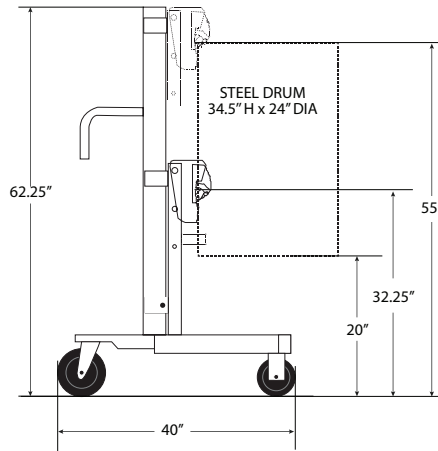

**F88577B3**  
Drum Lift with Strap Attachment

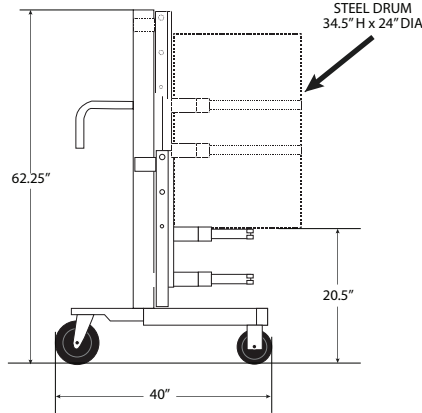

**F88576B4**  
Drum Lift with Cylinder Attachment

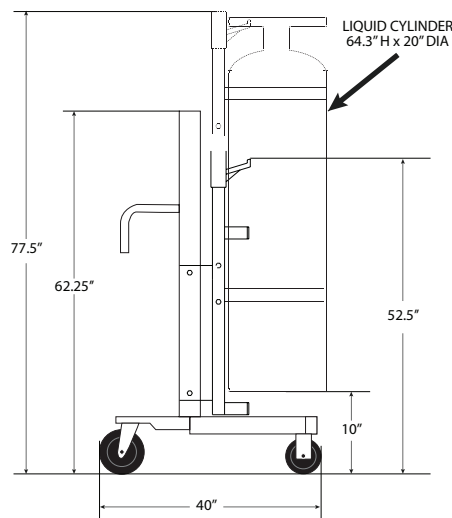

### Attachments available as accessories:



**F63877A5**

**Beak Attachment**

Gravity actuated beak grips & lifts from the rim of your container. Works well on a variety of containers where the rim & drum are strong enough to support the weight.

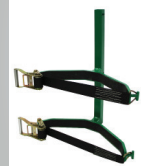

**F64657A7**

**Strap Attachment**

Dual ratchet strap assemblies allow this attachment to lift a variety of containers 14-24" in diameter.



**F69282A7**

**Cylinder Attachment**

Dual ratchet strap attachment designed specifically for compressed gas and cryogenic tanks. Also works well on a variety of other tall containers (9-18" in diameter).

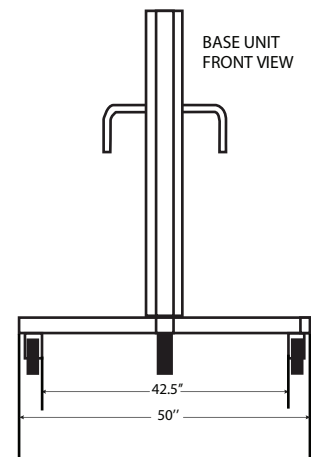
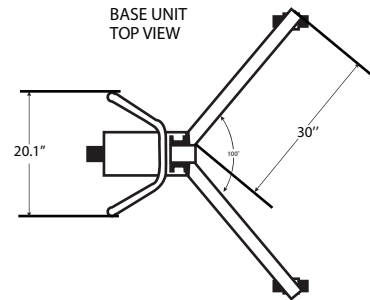

# Drum Lift

WITH TELESCOPING LEGS - BARREL HAWK



Valley Craft's Drum Lift with telescoping legs comes standard with an attachment of your choice and offers an overall load capacity of 800 pounds and maximum lift height of 18". The gravity actuated beak grips and lifts from the rim and drum and works well for a variety of containers, as long as the rim and drum are strong enough to support the weight of the load. Equipped with adjustable legs and a hand-operated, pallet-jack style hydraulic lift, this drum lifter is extremely versatile and maneuverable. Telescoping legs can be adjusted for transportation as load center permits. The universal quick-release backplate allows the unit to work well with other available attachments: F64657A7 Strap Attachment Accessory and F69282A7 Cylinder Attachment Accessory. Durable powder coat finish in Green.

Function			
Part Number	F89265	F89264	F89263
Name	Drum Lift w/ Beak Attmt	Drum Lift w/ Strap Attmt	Drum Lift w/ Cylinder Attmt
Load Capacity	800 lbs	800 lbs	800 lbs
Weight	372 lbs	372 lbs	372 lbs
Width	50"	50"	50"
Length	40"	40"	40"
Height	63"	63"	63"
Max Lift Travel	18"	18"	18"



**F89265**  
Drum Lift with Beak Attachment

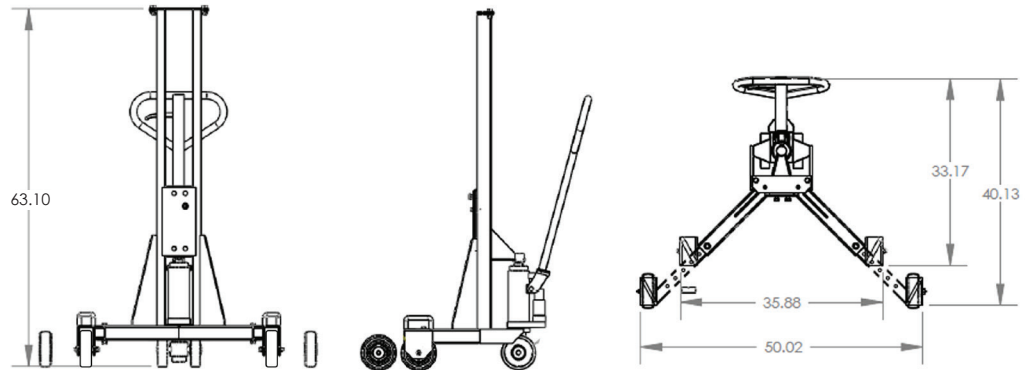

**F89264**  
Drum Lift with Strap Attachment



**F89263**  
Drum Lift with Cylinder Attachment



**Attachments available as accessories:**



**F63877A5**

**Beak Attachment**  
Gravity actuated beak grips & lifts from the rim of your container. Works well on a variety of containers where the rim & drum are strong enough to support the weight.



**F64657A7**

**Strap Attachment**  
Dual ratchet strap assemblies allow this attachment to lift a variety of containers 14-24" in diameter.



**F69282A7**

**Cylinder Attachment**  
Dual ratchet strap attachment designed specifically for compressed gas and cryogenic tanks. Also works well on a variety of other tall containers (9-18" in diameter).



# Powered Aluminum Lift

The Powered Aluminum Lift from Valley Craft allows for safe and efficient lifting and transportation of heavy materials. The aluminum lift has a 500-lb load capacity and an overall height of 81", the powered aluminum lift is capable of fitting through standard doorways. The slim profile makes maneuvering in narrow and confined spaces easy. The unit is also equipped with overload protection for operator safety and equipment protection.



## FEATURES

- Light-weight aluminum construction
- Ergonomic handle
- Motor control with variable lift speeds up to 2 inches per second
- Smooth and precise lifting with ball screw lift mechanism
- Quick attachment end-effectors
- Built-in battery charger
- Battery capacity: 24V DC, 18Ah
- Battery gauge
- Total Lift Stroke: 53½"
- Weight overload protection
- See-through safety shield
- Custom end effectors available



Convenient On-Board charging station.



Simple control panel for easy use and training.



Quick change mounting plate for end effectors.

Model	Description	Overall Dimensions (L x W x H)	Load Capacity (lbs)	Product Weight (lbs)
F89398	Powered Aluminum Lift	38 x 29 x 81"	500	240
F89390	Wide Platform Attachment	13 x 26" Platform	500	19
F89354	Narrow Platform Attachment	20 x 16¼" Platform	500	18
F80106A8	Mandrel End Attachment	21½" L x 2½" Diameter	500	10

## Attachments



Wide Platform end effector for lifting boxes and other flat based objects.



Narrow Platform end effector perfect for lifting servers.



Mandrel end effector for lifting coils and rolls.

# Drum, Pallet, Box Lift

VERSA LIFT, MANUAL DRIVE



An efficient multi-purpose positioner with a single-post design to provide high visibility. Available in 78" or 90" models, with several power options: manual foot pump, air motor, 110-volt AC motor, or 12-volt DC motor. Optional floor lock available. Unit does not come with a drum handling attachment - choose from options (purchased separately) shown below: Drum Grip, Drum Claw, Drum Rotator, Pallet Forks, Drum Tilter, and Steel Platform. 800-lbs load capacity.



**F88567B5**  
78" Straddle Versa Lift  
(No Attachment)

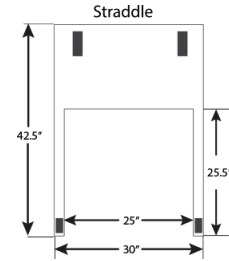

**F89410A2**  
Optional floor lock will keep the lift in place while attaching or unattaching load/attachment



Part Number	F88553C1	F88561C1	F88567B5	F88568B4	F87022B6	F87040B4
Name	78" Straddle	90" Straddle	78" Straddle	90" Straddle	78" Straddle	90" Straddle
Load Capacity	800 lbs	800 lbs	800 lbs	800 lbs	800 lbs	800 lbs
Weight	467 lbs	489 lbs	335 lbs	357 lbs	335 lbs	380 lbs
Width	30"	30"	30"	30"	30"	30"
Length	42½"	42½"	42½"	42½"	42½"	42½"
Height	78"	90"	78"	90"	78"	90"
Lift Speed	3.4"/sec	3.4"/sec	1"/sec	1"/sec	3.4"/sec	3.4"/sec
Max lift travel	58"	71"	58"	71"	58"	71"
Turning Radius	44"	44"	44"	44"	44"	44"

## Lift Attachments

Function	S LIFT	S LIFT	F P S LIFT ROTATE	F P S LIFT	LIFT	LIFT
Part Number	F86146A9	F88560A2	F89156	F89409A5	F89406A8	F89418A4
Name	Drum Grip	Drum Claw	Drum Rotator	Drum Tilter	Pallet Forks	Steel Platform
Load Capacity	800 lbs	800 lbs	800 lbs	800 lbs	800 lbs	800 lbs
Weight	108 lbs	56 lbs	122 lbs	66 lbs	43 lbs	24 lbs
Drum Diameter	18 - 23"	18 - 28"	14 - 24"	14 - 24"		
Fork Length					24"	
Platform Size						24 x 24"
Features	Spring & cam-actuated to automatically grip as pressure against drum forces jaws down.	Beak-style grab that grasps the rim of virtually any kind of drum. Attaches without the use of straps. 13"W x 9"D x 32"H	Includes nylon belts, ratchet tighteners and rubber-coated arms. Rotate speed of 2 RPM.	Rotates 120°. Hand crank-operated tilter includes ratchets with nylon straps.	Move, elevate and stack pallets up to 24" deep. Useful as compact fork truck in congested areas and narrow aisles. 3"W x 24"D x 17"H	Use with Pallet Forks (F89406A8) to make into a platform lift for work positioning and heavy items. 24"W x 24"D x 17"H (when in place with Pallet Forks)



# Drum Strap, Lift, Rotate



ROTO LIFT, MANUAL DRIVE

Transport, lift, and rotate most steel, plastic, and fiber drums and cylinders 14"-24" in diameter. Rotates full 360°. Available in 78" or 90" models, straddle or counter-weighted, and offer different power sources: manual, battery, air, or 110V AC. Battery-powered models require 12-volt deep cycle battery (included) and plugs into a standard grounded outlet. Air-powered models are ideal for spark-resistant applications and require outside air source. Optional floor lock available. 800-lb. load capacity. Counter-weighted models are designed to butt directly up against pallets to make loading and unloading safe and effective. Counter-weighted models are twice as heavy and require more effort to move.

## Counter Weighted



**F88569C3**  
78" Counter Weighted Lift

Part Number	F88569C3	F88570C0	F88580B8	F88581B7
Name	78" Counter	90" Counter	78" Counter	90" Counter
Load Capacity	800 lbs	800 lbs	800 lbs	800 lbs
Weight	1075 lbs	1101 lbs	985 lbs	1,010 lbs
Width	30"	30"	30"	30"
Length	37.25"	37.25"	37.25"	37.25"
Height	78"	90"	78"	90"
Lift Speed	3.4"/sec	3.4"/sec	1"/sec	1"/sec
Rotate Speed	6 RPM	6 RPM	2 RPM	2 RPM
Max lift travel	58"	71"	58"	71"
Turning Radius	61"	61"	61"	61"

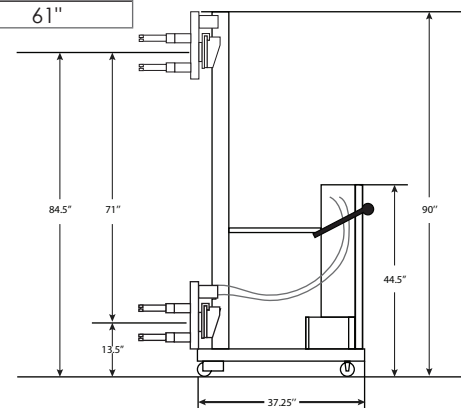
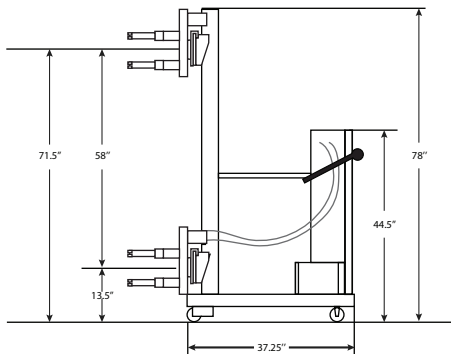
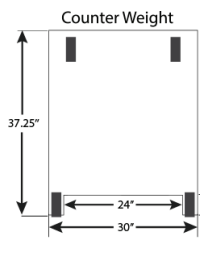

## Straddle

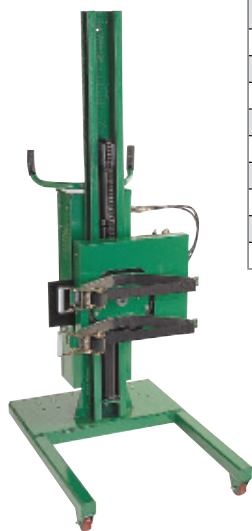

**F88565C7**  
78" Straddle Lift

Part Number	F88565C7	F88566C6	F88563B9	F88564B8	F88589B9	F88590B6
Name	78" Straddle	90" Straddle	78" Straddle	90" Straddle	78" Straddle	90" Straddle
Load Capacity	800 lbs	800 lbs	800 lbs	800 lbs	800 lbs	800 lbs
Weight	510 lbs	525 lbs	415 lbs	430 lbs	445 lbs	460 lbs
Width	30"	30"	30"	30"	30"	30"
Length	42.5"	42.5"	42.5"	42.5"	42.5"	42.5"
Height	78"	90"	78"	90"	78"	90"
Lift Speed	3.4"/sec	3.4"/sec	1"/sec	1"/sec	3.4"/sec	3.4"/sec
Rotate Speed	6 RPM	6 RPM	2 RPM	2 RPM		
Max lift travel	58"	71"	58"	71"	58"	71"
Turning Radius	44"	44"	44"	44"	44"	44"

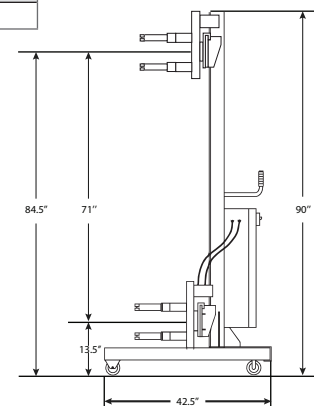
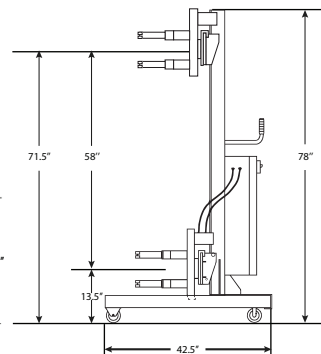
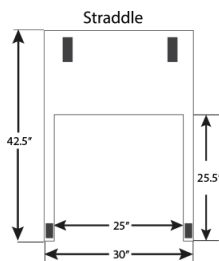



# Drum Clamp, Lift, Rotate



ROTO GRIP, MANUAL DRIVE

Lift and rotate most steel drums and cylinders (18"-24" in diameter) with electric clamping jaws. Choose from 78" or 90" models, straddle or counter-weighted. All units are manually propelled and feature an electric-over-hydraulic control system. Electric screw jack clamps and releases the rubber-lined jaws while the hydraulic rotator turns drums 360°. Single mast design allows for high visibility, 800-lb. load capacity. Optional floor lock available. Electric-over-hydraulic control system requires 12-volt deep cycle battery (included) and plugs into a standard grounded outlet. Counter-weighted model is designed to butt directly up against pallets for effective loading and unloading. Counter-weighted models weigh twice as much as straddle-type models and require more effort to move.

Part Number	F88587C1	F88588C0	F88585C3	F88586C2
Name	78" Counter	90" Counter	78" Straddle	90" Straddle
Load Capacity	800 lbs	800 lbs	800 lbs	800 lbs
Weight	1150 lbs	1200 lbs	560 lbs	590 lbs
Width	30"	30"	30"	30"
Length	62"	62"	45"	45"
Height	78"	90"	78"	90"
Drum Diameter	18 - 24"	18 - 24"	18 - 24"	18 - 24"
Lift Speed	3.4"/second	3.4"/second	3.4"/second	3.4"/second
Rotate Speed	6 RPM	6 RPM	6 RPM	6 RPM
Max lift travel	58"	71"	58"	71"
Turning Radius	65"	65"	44"	44"



**F88587C1**  
78" Counter  
Weighted Lift

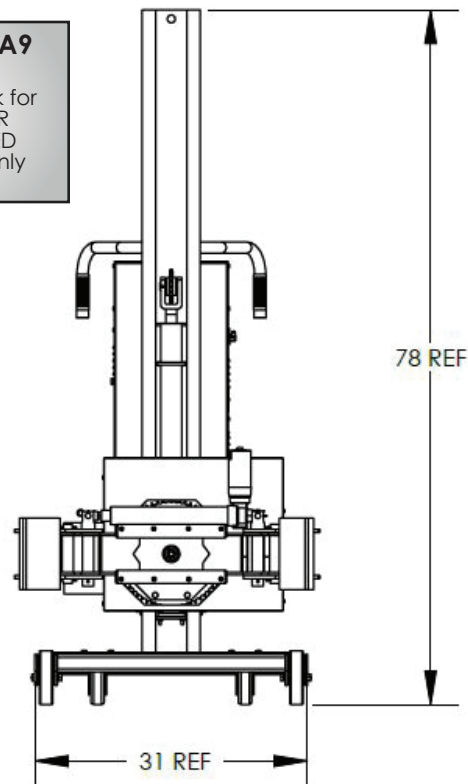
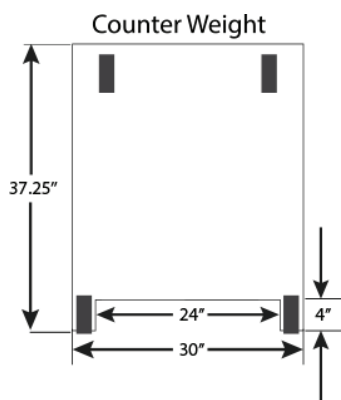

**F88585C3**  
78" Straddle Lift

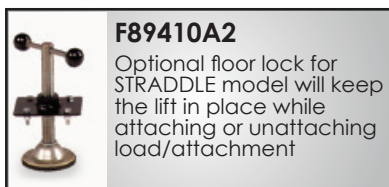
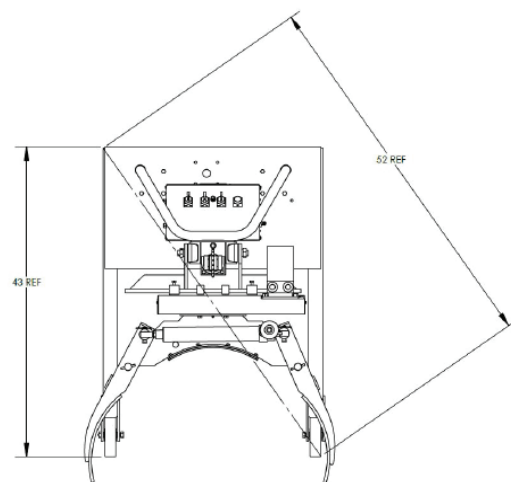
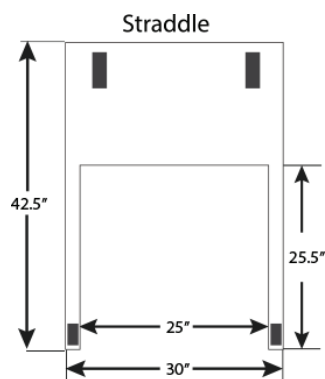

Professional Grade Quality....Built to Last....Made in the U.S.A.

# Drum, Pallet, Box Lift

VERSA LIFT, POWER DRIVE



Multi-purpose positioner that rolls easily on (2) 3" rigid and (1) 12" swivel poly wheels. Efficiently performs duties and is extremely versatile. Unit does not come with an attachment - choose from options (purchased separately) shown below: Drum Grip, Drum Claw, Drum Rotator, Pallet Forks, Drum Tilter, and Steel Platform. Includes two batteries and 120V AC charger.

Part Number	F80136A9
Name	78" Counter
Load Capacity	1,000 lbs
Weight	1,150 lbs
Width	32"
Length	49"
Height	78"
Drive Speed	1 - 2.5 MPH
Lift Speed	17 FPM
Max lift travel	58"
Turning Radius	71"
Drum Diameter	14 - 24"
Rotate Speed	6 RPM
Jaw Size	9 x 15"

**F80136A9**  
78" Counter-weight  
Versa Lift



Counter Weight

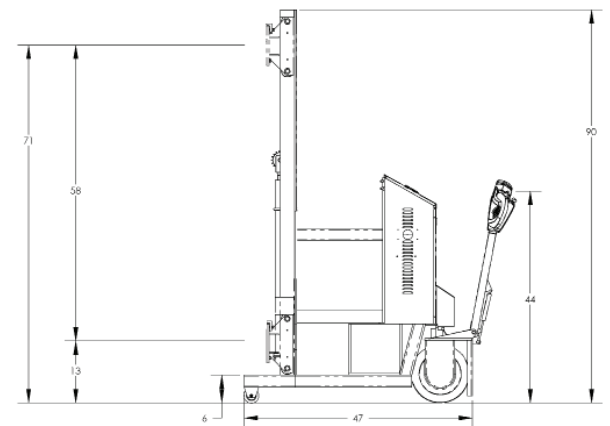
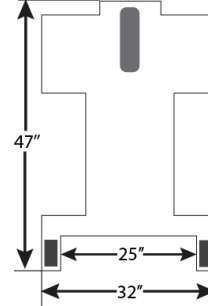

## Lift Attachments

Function						
Part Number	F86146A9	F88560A2	F89156	F89409A5	F89406A8	F89418A4
Name	Drum Grip	Drum Claw	Drum Rotator	Drum Tilter	Pallet Forks	Steel Platform
Load Capacity	800 lbs	800 lbs	800 lbs	800 lbs	800 lbs	800 lbs
Weight	108 lbs	56 lbs	122 lbs	66 lbs	43 lbs	24 lbs
Drum Diameter	18 - 23"	18 - 28"	14 - 24"	14 - 24"		
Fork Length					24"	
Platform Size						24 x 24"
Features	Spring & cam-actuated to automatically grip as pressure against drum forces jaws down.	Beak-style grab that grasps the rim of virtually any kind of drum. Attaches without the use of straps. 13"W x 9"D x 32"H	Includes nylon belts, ratchet tighteners and rubber-coated arms. Rotate speed of 2 RPM.	Rotates 120°. Hand crank-operated tilter includes ratchets with nylon straps.	Move, elevate and stack pallets up to 24" deep. Useful as compact fork truck in congested areas and narrow aisles. 3"W x 24"D x 17"H	Use with Pallet Forks (F89406A8) to make into a platform lift for work positioning and heavy items. 24"W x 24"D x 17"H (when in place with Pallet Forks)

# Drum Strap, Lift, Rotate

ROTO LIFT, POWER DRIVE



Roto-Lift drum handlers lift, rotate, and dump most steel, fiber, and plastic drums and cylinders (14" -24" in diameter) with ratchet straps. Transporting, lifting, and rotating drums and containers is safer and easier than ever before with the power drive Roto-Lift. 12" power drive wheels plus full-function hydraulic lift and pour means any operator can effortlessly move drums up to 1,000-lbs. A powered drum handler can provide substantial cost savings by eliminating the need for fork lifts. These units feature fully adjustable and programmable controls with 1-2.5 mph speed controls (2.5 mph factory set max) and can easily handle grades up to 5-degrees. Features a 24-volt DC system, battery indicator gauge, and a keyed On/Off switch. Includes two batteries and 12V AC charger.

Part Number	F89832A5	F89831A4	F89838A2	F89837A1
Name	78" Counter	90" Counter	78" Straddle	90" Straddle
Load Capacity	1,000 lbs	1,000 lbs	1,000 lbs	1,000 lbs
Weight	1,400 lbs	1,450 lbs	750 lbs	800 lbs
Width	32"	32"	30"	32"
Length	53"	53"	47"	47"
Height	78"	90"	78"	90"
Drum Diameter	14 - 24"	14 - 24"	14 - 24"	14 - 24"
Drive Speed	1 - 2.5 MPH	1 - 2.5 MPH	1 - 2.5 MPH	1 - 2.5 MPH
Lift Speed	3.4" / second	3.4" / second	3.4" / second	3.4" / second
Rotate Speed	6 RPM	6 RPM	6 RPM	6 RPM
Max lift travel	58"	71"	58"	71"
Turning Radius	71"	71"	48"	48"



**F89832A5**  
78" Counter  
Roto Lift

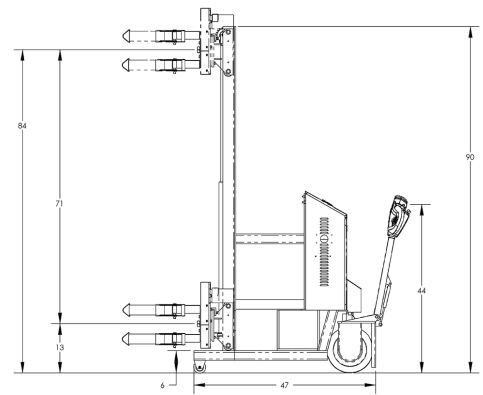
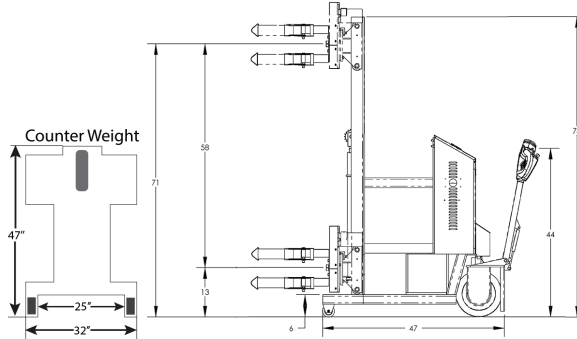

**F89838A2**  
78" Straddle  
Roto Lift

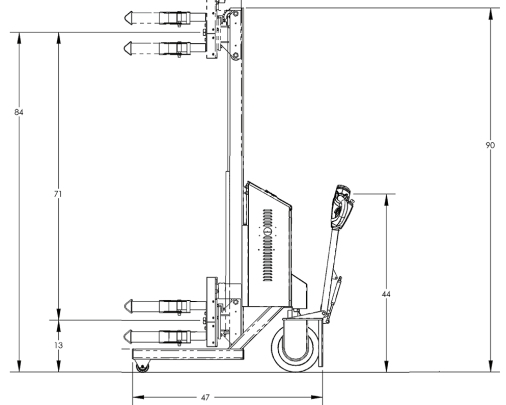
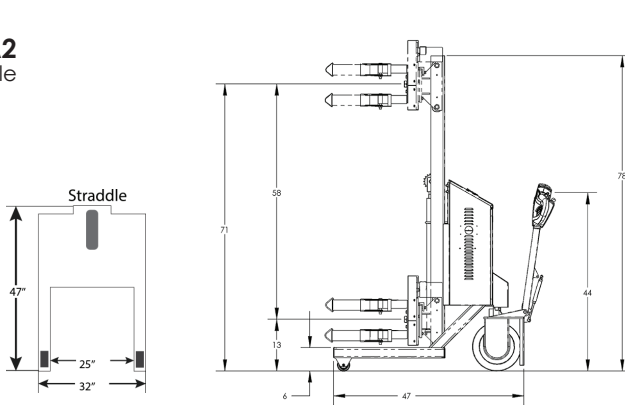

Curtis TM-1 Tiller head equipped with emergency reverse switch, electronic throttle, rocker switches, horn, and gas spring to automatically return head to upright position when not in use.



Professional Grade Quality....Built to Last....Made in the U.S.A.

# Drum Clamp, Lift, Rotate

ROTO GRIP, POWER DRIVE



This counter-weighted model is designed to butt directly up against pallets and containment skids. This drum handler can easily maneuver grades up to 5-degrees and has a turning radius of 71 inches. Hydraulic clamping jaws allow for 360-degree rotation. The telescoping mast allows for easy access in and out of standard doorways, and also provides better operator viewing while transporting loads. Maximum lift height from center of jaws to floor is 84 inches. Features variable drive speed (2.5 mph factory set max), 24-volt DC system and battery indicator gauge. Includes two 12-volt deep-cycle batteries and 12V AC charger.

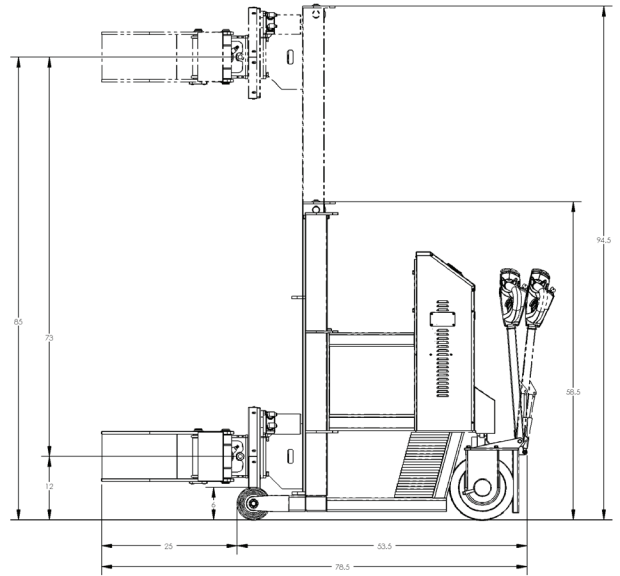

Curtis TM-1 Tiller head equipped with emergency reverse switch, electronic throttle, rocker switches, horn, and gas spring to automatically return head to upright position when not in use.

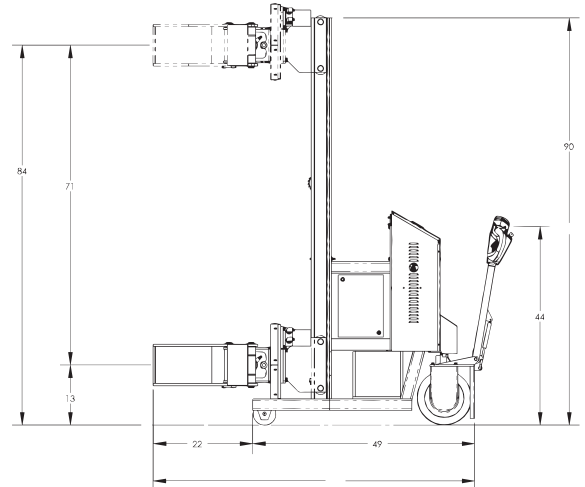
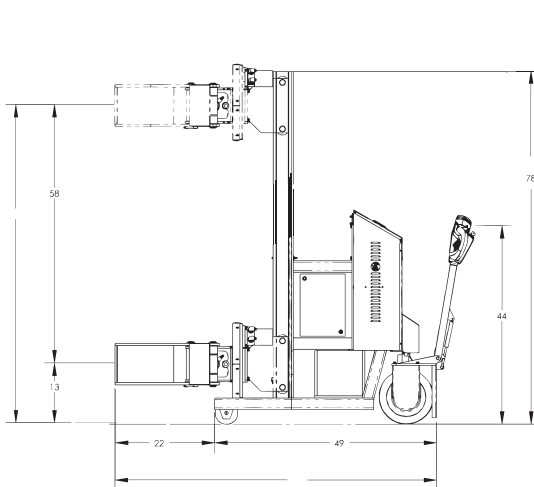
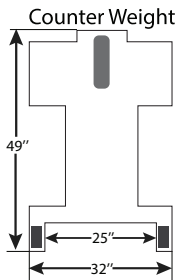
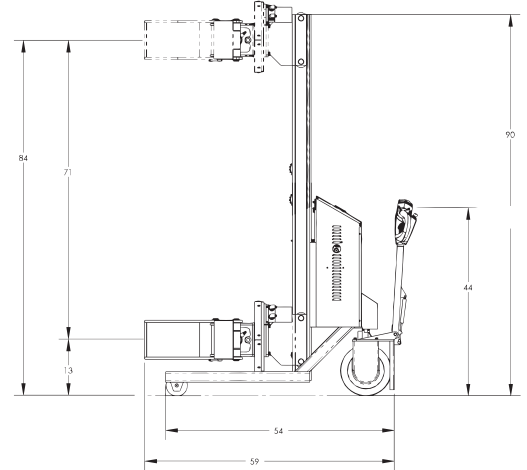
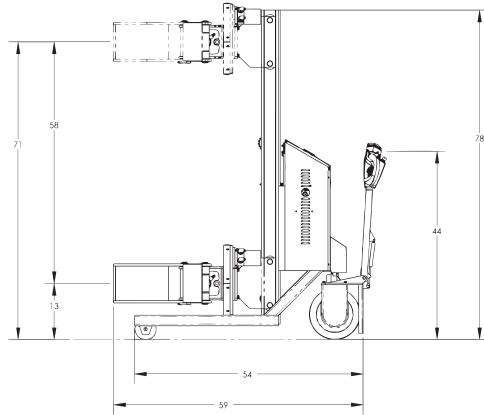
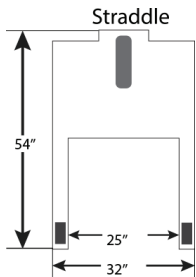

## Telescopic

Part Number	F89529
Name	Roto Grip, Telescopic
Load Capacity	1,000 lbs
Weight	1,619 lbs
Width	38"
Length	79"
Height	58½ - 94½"
Jaw Size	9 x 15"
Drum Diameter	18 - 28"
Lift Speed	17 FPM
Rotate Speed	6 RPM
Max lift travel	73"
Turning Radius	71"
Top of Mast Height (Lowered)	58½"
Top of Mast Height (Extended)	94½"
Center of jaws to floor Range	12" - 85"

**F89529**  
Telescopic  
Roto Grip



## Straddle

Part Number	F80144A7	F80143A6
Name	78" Straddle	90" Straddle
Load Capacity	1,000 lbs	1,000 lbs
Weight	700 lbs	750 lbs
Width	32"	32"
Length	59"	59"
Height	78"	90"
Jaw Size	9 x 15"	9 x 15"
Drum Diameter	18 - 28"	18 - 28"
Lift Speed	17 FPM	17 FPM
Rotate Speed	6 RPM	6 RPM
Max lift travel	58"	71"
Turning Radius	48"	48"
Center of jaws to floor Range	13 - 71"	13 - 84"

**F80144A7**  
78" Straddle Roto Grip



## Counter Weighted

Part Number	F80146A9	F80145A8
Name	78" Counter	90" Counter
Load Capacity	1,000 lbs	1,000 lbs
Weight	1,150 lbs	1,200 lbs
Width	32"	32"
Length	71"	71"
Height	78"	90"
Jaw Size	9 x 15"	9 x 15"
Drum Diameter	18 - 28"	18 - 28"
Lift Speed	17 FPM	17 FPM
Rotate Speed	6 RPM	6 RPM
Max lift travel	58"	71"
Turning Radius	71"	71"
Center of jaws to floor Range	13 - 71"	13 - 84"

**F80146A9**  
78" Counter Roto Grip



## Drum Clamp

MAXI GRIP, SELF-POWERED



- Handles Steel, Plastic, and Fiber Drums

A single-function grip designed to handle most plastic, steel & fiber containers (18"-28" diameter) and to increase efficiency of basic moving, stacking and palletizing actions. This unit has no tilting or rotating functions, but is optimal for fast and effective warehousing drum inventories. Equipped with built-in, 12-volt, battery-operated Power-Pak and self-contained hydraulics. Features system pressure and battery discharge gauges. Includes corded control box.

Note: Batteries & Charger are included.

Part Number	F89705
Name	Maxi Grip, Self-Powered
Load Capacity	2,000 lbs
Weight	673 lbs
Width	34"
Length	60"
Height	17"
Distance Between Fork Pockets	19 <sup>3</sup> / <sub>8</sub> "
Fork Pocket Size	6 <sup>1</sup> / <sub>2</sub> "W x 1 <sup>3</sup> / <sub>4</sub> -2 <sup>1</sup> / <sub>2</sub> "H x 37 <sup>1</sup> / <sub>2</sub> "L
Jaw Size	15"L x 9"H
Drum Diameter	18 - 28"

**F89705**  
Maxi Grip

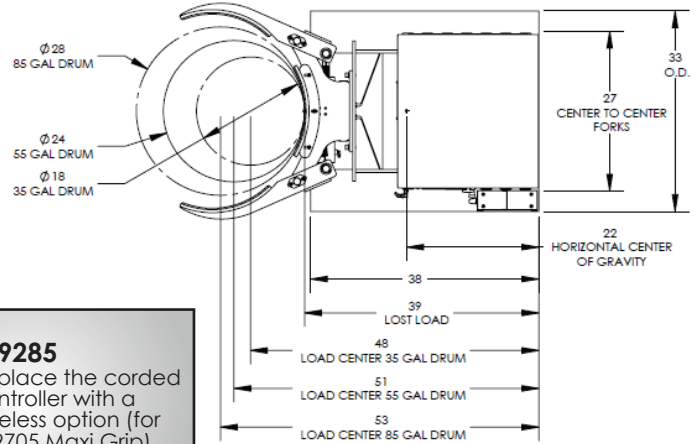

## Drum Clamp

MAXI GRIP, LIFT TRUCK POWERED



- Handles Steel, Plastic, and Fiber Drums

This single-function grip designed to handle most plastic, steel & fiber containers (18"-28" diameter) and to increase efficiency of basic moving, stacking and palletizing actions. This unit has no tilting or rotating functions, but is optimal for fast and effective warehousing drum inventories. Unit is fork-mounted and requires that the lift truck be equipped with auxiliary valve control and hydraulic quick couplers for operation.

Part Number	F89704
Name	Maxi Grip, Lift Truck Powered
Load Capacity	2,000 lbs
Weight	454 lbs
Width	34"
Length	60"
Height	14"
Distance Between Fork Pockets	19 <sup>3</sup> / <sub>8</sub> "
Fork Pocket Size	6 <sup>1</sup> / <sub>2</sub> "W x 1 <sup>3</sup> / <sub>4</sub> -2 <sup>1</sup> / <sub>2</sub> "H x 37 <sup>1</sup> / <sub>2</sub> "L
Jaw Size	15"L x 9"H
Drum Diameter	18 - 28"

**F89704**  
Maxi Grip

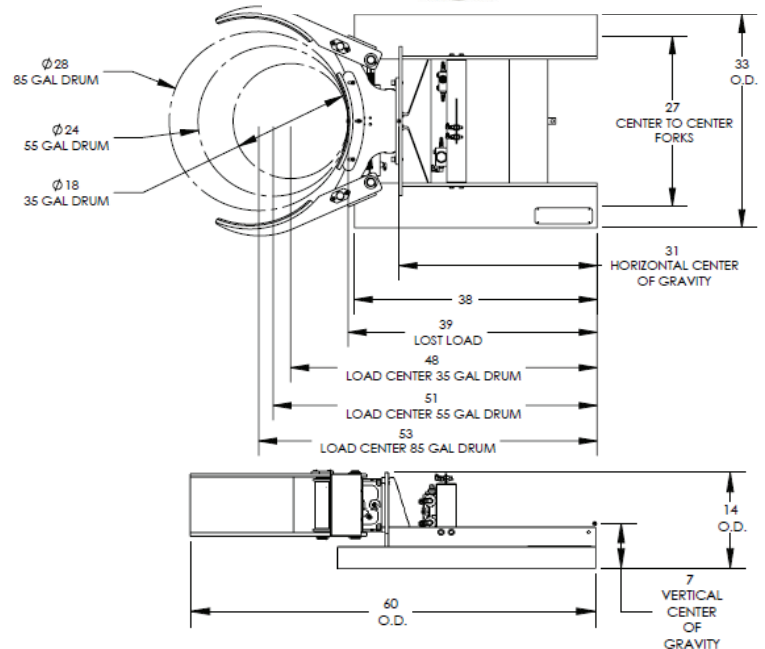

# Drum Clamp, Rotate

HYDRA GRIP, SELF-POWERED



- Handles Steel, Plastic, and Fiber Drums
- 360° Rotation (Both Directions)

An industry exclusive to Valley Craft, the self-powered clamp & rotate provides two fully hydraulic functions that are activated by an ergonomic hand-held pendant. A single set of fully hydraulic jaws automatically adjusts to most drum diameters (18" - 28"). Rotating function offers full 360° rotation for inverting and pouring to both the right and left. Features system pressure gauge and battery discharge indicator with hour meter and clock. Equipped with built-in, 12-volt, battery-operated Power-Pack and self contained hydraulics. Includes corded control box.

Note: Batteries & Charger are included.

Part Number	F89703
Name	Hydra Grip, Self-Powered
Load Capacity	2,000 lbs
Weight	798 lbs
Width	34"
Length	66"
Height	17"
Distance Between Fork Pockets	19 <sup>5</sup> / <sub>8</sub> "
Fork Pocket Size	6 <sup>1</sup> / <sub>2</sub> "W x 1 <sup>3</sup> / <sub>4</sub> -2 <sup>1</sup> / <sub>2</sub> "H x 37 <sup>1</sup> / <sub>2</sub> "L
Jaw Size	15"L x 9"H
Drum Diameter	18 - 28"

**F89703**  
Hydra Grip

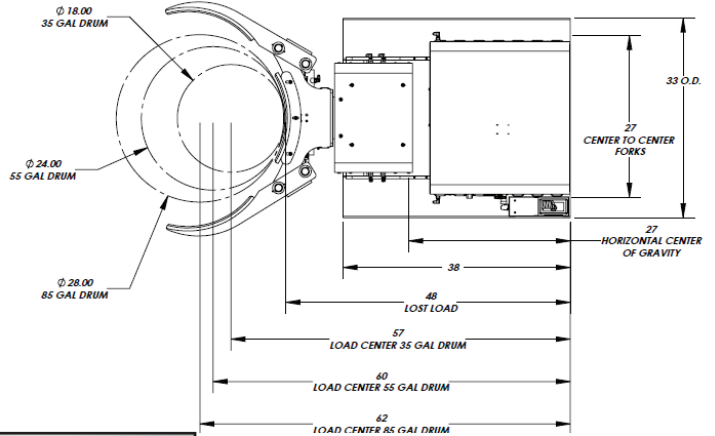

**F89157**  
Replace the corded controller with a wireless option (for F89703 Hydra Grip).

# Drum Clamp, Rotate

HYDRA GRIP, LIFT TRUCK POWERED



- Handles Steel, Plastic, and Fiber Drums
- 360° Rotation (Both Directions)

Unit provides two fully hydraulic functions - clamp and rotate. A single set of fully hydraulic jaws automatically adjust to most drum diameters (18" - 28"). Rotating function offers full 360° rotation for inverting and pouring to both the right and left. Unit requires lift truck equipped with auxiliary valve control and hydraulic quick couplers for operation.

\*Note: The clamp/unclamp feature is accomplished via a rope pull activation of the selector valve.

Part Number	F89702
Name	Hydra Grip, Lift Truck Powered
Load Capacity	2,000 lbs
Weight	591 lbs
Width	34"
Length	68"
Height	19"
Distance Between Fork Pockets	19 <sup>5</sup> / <sub>8</sub> "
Fork Pocket Size	6 <sup>1</sup> / <sub>2</sub> "W x 1 <sup>3</sup> / <sub>4</sub> -2 <sup>1</sup> / <sub>2</sub> "H x 37 <sup>1</sup> / <sub>2</sub> "L
Jaw Size	15"L x 9"H
Drum Diameter	18 - 28"

**F89702**  
Hydra Grip

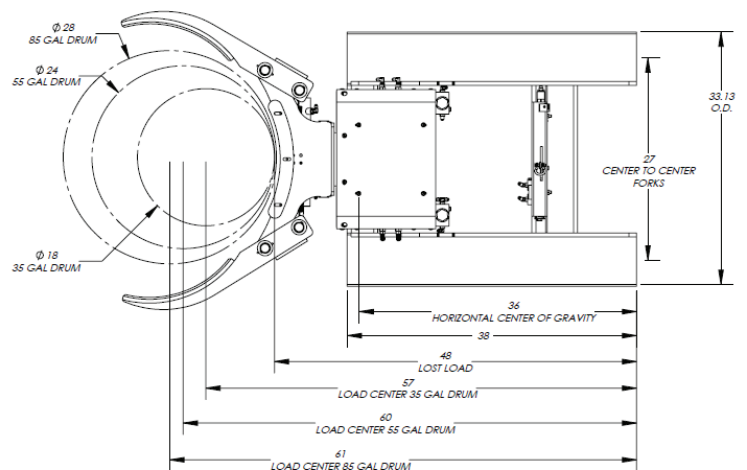

Professional Grade Quality....Built to Last....Made in the U.S.A.

## Drum Clamp, Tilt

VERSA GRIP, SELF-POWERED



- Handles Steel, Plastic, and Fiber Drums
- 120° Forward Tilt

Valley Craft's answer to drum placement and pouring. This unit features hydraulic gripping and 120° forward tilting capabilities for moving and pouring most steel and fiber drums (18"-28"). Equipped with built-in, 12-volt, battery-operated Power-Pak and self-contained hydraulics. Features system pressure and battery discharge gauges. Includes corded control box.

Note: Batteries & Charger are included.

Part Number	F89701
Name	Versa Grip, Self-Powered
Load Capacity	2,000 lbs
Weight	813 lbs
Width	34"
Length	67"
Height	17"
Distance Between Fork Pockets	19 <sup>3</sup> / <sub>8</sub> "
Fork Pocket Size	6 <sup>1</sup> / <sub>2</sub> "W x 1 <sup>3</sup> / <sub>4</sub> -2 <sup>1</sup> / <sub>2</sub> "H x 37 <sup>1</sup> / <sub>2</sub> "L
Jaw Size	15"L x 9"H
Drum Diameter	18 - 28"

F89701  
Versa Grip

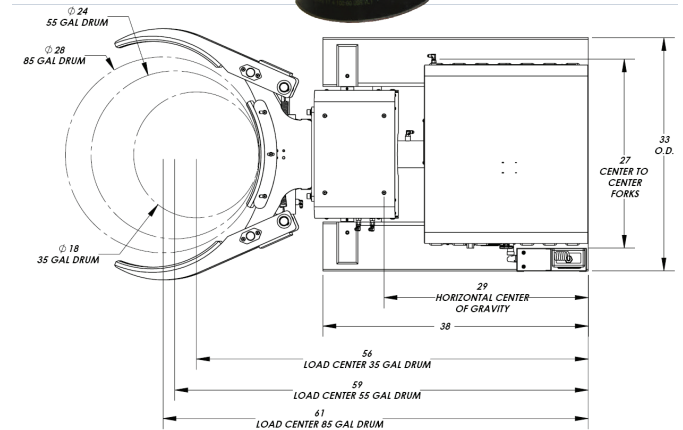

**F89158**  
Replace the corded controller with a wireless option (for F89701 Versa Grip).

## Drum Clamp, Tilt

VERSA GRIP, LIFT TRUCK POWERED



- Handles Steel, Plastic, and Fiber Drums
- 120° Forward Tilt

Features gripping and 120° forward dumping capabilities for moving and pouring steel and fiber drums (18"-28" diameter). Unit requires lift truck be equipped with auxiliary valve control and hydraulic quick couplers for operation.

\*Note: The clamp/unclamp feature is accomplished via a rope pull activation of the selector valve.

Part Number	F89700
Name	Versa Grip, Lift Truck Powered
Load Capacity	2,000 lbs
Weight	596 lbs
Width	33"
Length	67"
Height	19"
Distance Between Fork Pockets	19 <sup>3</sup> / <sub>8</sub> "
Fork Pocket Size	6 <sup>1</sup> / <sub>2</sub> "W x 1 <sup>3</sup> / <sub>4</sub> -2 <sup>1</sup> / <sub>2</sub> "H x 37 <sup>1</sup> / <sub>2</sub> "L
Jaw Size	15"L x 9"H
Drum Diameter	18 - 28"

F89700  
Versa Grip

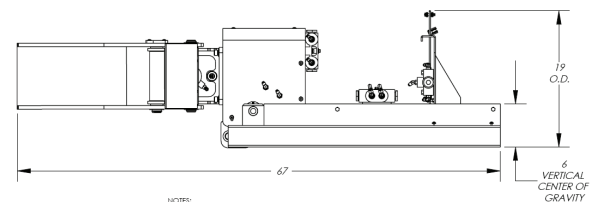
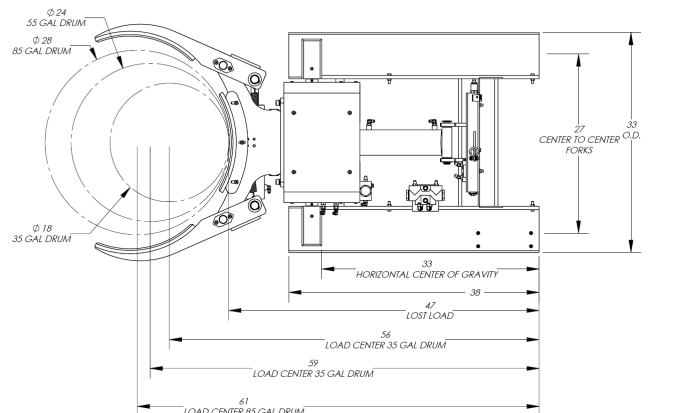

NOTES:



# Drum Clamp, Rotate, Tilt

ULTRA GRIP, SELF-POWERED



**F89815A5**  
Ultra Grip

- Handles Steel, Plastic, and Fiber Drums
- 120° Forward Tilt
- 360° Rotation (Both Directions)
- Variable Speed

Only the fork-mounted Ultra Grip provides the operator with controlled three-way proportional tilting capabilities to the left, right and forward while also offering the basic functions of inverting, moving, stacking and palletizing drums. The Ultra Grip handles most drum types (18" - 28" diameter) and its sleek, tapered design allows for better viewing of the jaws and load. This user friendly design includes access panels for ease of maintenance and infinitely variable speed control for safer, more efficient drum handling.

Note: Batteries & Charger are included.

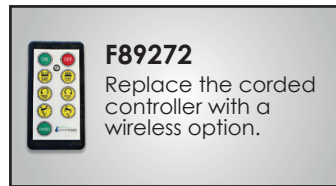
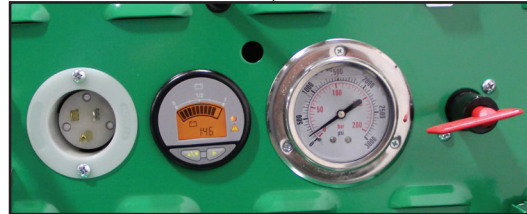
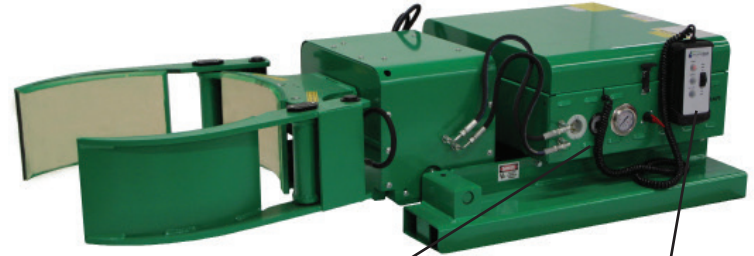

Magnetic Back

Part Number	F89815A5
Name	Ultra Grip, Self-Powered
Load Capacity	2,000 lbs
Weight	891 lbs
Width	34"
Length	69"
Height	17"
Distance Between Fork Pockets	19 3/4"
Fork Pocket Size	6 1/2"W x 1 3/4"-2 1/2"H x 37 1/2"L
Jaw Size	15"L x 9"H
Drum Diameter	18 - 28"

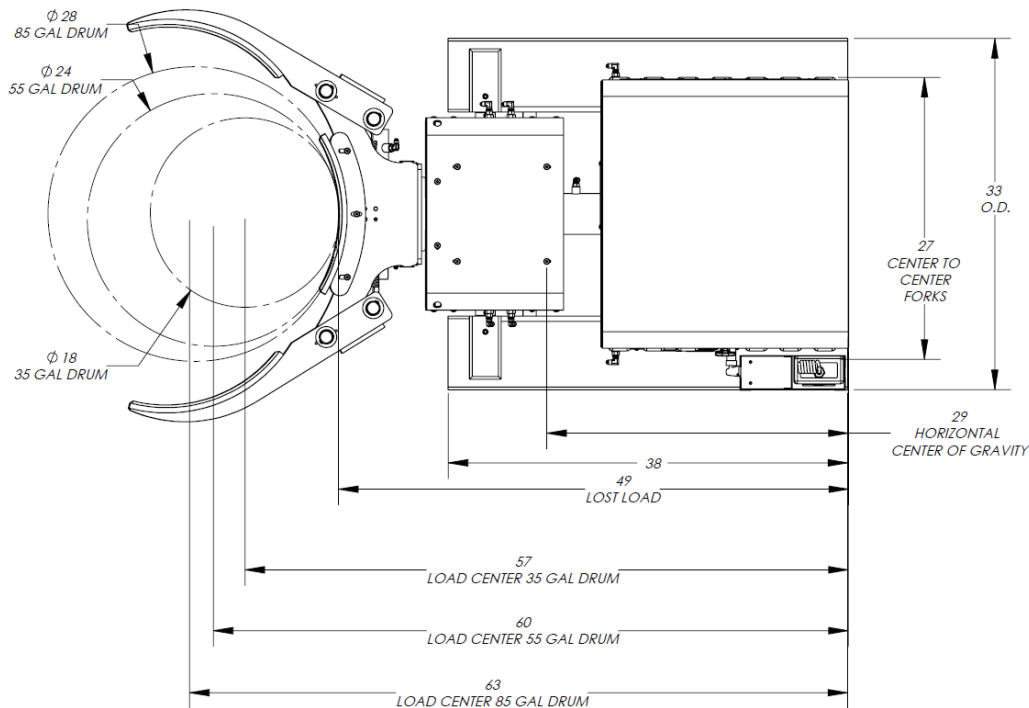

\*Caution should be used when clamping thin walled drums, open topped drums & smooth sided drums.



Professional Grade Quality....Built to Last....Made in the U.S.A.

SKID STEER

## Drum Clamp, Rotate



Allows operator to handle drums at reclamation areas, construction landfills and any other location where drums and loaders are necessary. The drum handler hydraulically clamps and dumps most drums (18"-28" diameter). Attachment allows for continuous 360° rotation in either direction. Constant hydraulic pressure secures the load, making the unit excellent for salvage operations. Includes rubber-lined jaws, hoses, and standard ½" quick couplers.

*\*\*Note: The clamp/unclamp feature is accomplished by activating the selector valve (via a rope pull) on top of the frame. When the rope is not being pulled, the same hydraulic lever will activate the rotating function.*

Part Number	F89698
Name	Skid Steer Drum Handler
Load Capacity	2,000 lbs
Weight	625 lbs
Width	52"
Length	45"
Height	22"
Jaw Size	15"L x 9"H
Drum Diameter	18 - 28"

**F89698**  
Skid Steer  
Drum Handler

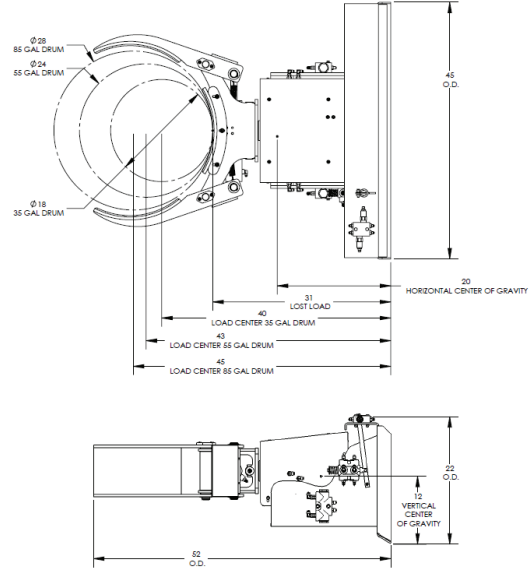

GRAVITY ACTUATED

## Steel Drum Grip



AUTO GRIP

Most efficient on consistently sized loads. Auto-Grip™ jaws are spring-and-cam actuated and equipped with jaws that grip with cam pressure that is proportional to drum weight. Jaws automatically grip when engaging drum and release when placing it on the floor. Standard jaws adjust to fit 30-, 55- or 85-gallon steel or over-pack drums, or any cylindrical object 18"-28" in diameter.

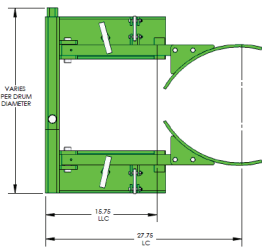

**F86145B0**  
Auto Grip

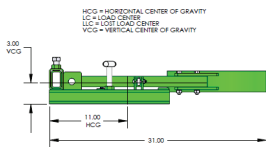

GRAVITY ACTUATED

## Plastic Drum Grip



AUTO GRIP

Auto Grip DH jaws grip under the top lip and adjust manually to grasp most plastic drums 22"-24" in diameter.



**F86165A5**  
Auto Grip DH

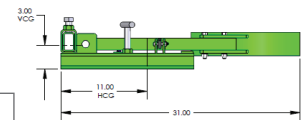
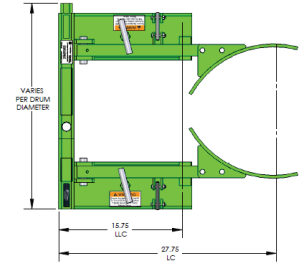

Part Number	F86145B0	F86165A5
Name	Steel Drum Grip	Plastic Drum Grip
Load Capacity	1,500 lbs	1,000 lbs
Weight	103 lbs	103 lbs
Width	33"	33"
Length	34"	34"
Height	7"	7"
Distance Between Fork Pockets	13 - 25"	17 - 21"
Fork Pocket Size	5 5/8"W x 1 5/8"H x 16 3/4"L	5 5/8"W x 1 5/8"H x 16 3/4"L
Jaw Size	3 x 15"	3 x 15"
Drum Diameter	18 - 28"	22 - 24"

ECONOMY

**Drum Grip** 

Gravity-actuated mechanical unit that handles consistently sized loads more efficiently than most hydraulic models. This unit is equipped with jaws that grip with cam pressure proportional to drum weight. Cam-actuated jaws automatically grip when engaging drum and release when placing it on the floor.

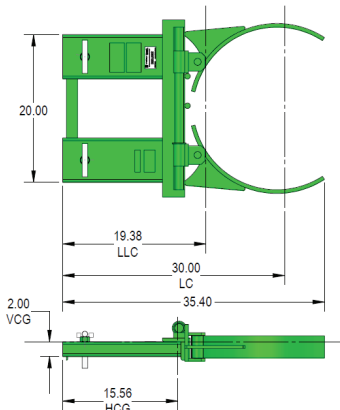

**F89743**  
Economy Drum Grip



ECONOMY

**Drum Snatcher** 

Economical and easy to use. Automatically grasps, then moves, stacks and palletizes standard 55-gallon steel drums 23"-24" in diameter, by utilizing unique knuckle-gripping system and natural pressure of the loaded drum. Designed for customers with limited drum handling needs. Fork-mounted.

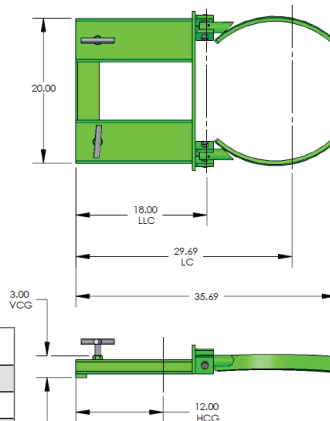

**F87398A2**  
Economy Drum Snatcher



Part Number	F89743	F87398A2
Name	Economy Drum Grip	Economy Drum Snatcher
Load Capacity	1,500 lbs	800 lbs
Weight	95 lbs	56 lbs
Width	24"	22"
Length	36"	36"
Height	7"	6"
Distance Between Fork Pockets	8"	8"
Fork Pocket Size	5 $\frac{5}{8}$ "W x 1 $\frac{1}{2}$ "H x 16 $\frac{3}{4}$ "L	5 $\frac{5}{8}$ "W x 1 $\frac{1}{2}$ "H x 16 $\frac{3}{4}$ "L
Jaw Size		
Drum Diameter	18 - 23 $\frac{1}{2}$ "	23 - 24"

FORKLIFT

**Beak Attachment** 

This attachment is equipped with powerful beak-style jaws that automatically grip when engaging drum and release when load is placed on floor. This product can manage most open or closed top drums having a chime or locking rings strong enough to support the weight of its own contents. Slides onto forks and secures via turn-down t-bolts. Handles most rimmed drums 24" in height or higher.



**F85370A0**  
Beak Attachment

FORKLIFT

**Strap Attachment**   

Straps conform to container to give maximum contact. Ratchet devices allow operator to apply exact tension force needed and reduces container damage. Allows user to pick up most any cylindrical object that is smooth-sided.



**F80147A7**  
Strap Attachment

Part Number	F85370A0	F80147A7
Name	Forklift Beak Attachment	Forklift Strap Attachment
Load Capacity	1,000 lbs	1,000 lbs
Weight	125 lbs	80 lbs
Width	24"	24"
Length	19"	19"
Height	38"	38"
Distance Between Fork Pockets	8"	9.5"
Fork Pocket Size	6 $\frac{1}{2}$ "W x 1 $\frac{1}{4}$ "H x 17"L	5 $\frac{5}{8}$ "W x 1 $\frac{1}{2}$ "H x 18"L



## Box Dumpers

Heavy Duty Box Dumpers bolt directly to the floor, ensuring reliability and stability throughout operation. Heavy-duty all-welded steel dumpers are designed to manage the heaviest of loads, ranging from 2,000 to 6,000 pounds load capacity. Dumpers are fully powered up and gravity down and contents dump completely within one minute to ensure time-efficient usage. Chutes have a 1/4" plate steel base with 7-ga. sides, and an adjustable hold down bar can be placed at 30-42" (on 2" centers). Hand pendant with magnetic back and durable, coiled cord simplify operator control.

Some commonly customized product features include casters, variable speed control, stainless steel material, 230V power option and higher dump heights.



Hand pendant front view



Magnetic back of hand pendant



**F80178A8**  
60" Box Dumper

### 2,000 LB Capacity

Model No.	Dump Height	Chute L x W	Chute Reach	Frame Width	Horizontal Clearance	Overhead Clearance	Weight (lbs)
F80193A3	36"	36 x 36"	12.5"	51"	72"	111"	1,226
F80184A4	36"	48 x 51"	12.5"	66"	81"	119"	1,525
F80190A0	48"	36 x 36"	10"	51"	79"	127"	1,400
F80181A1	48"	48 x 51"	10"	66"	87"	135"	1,575
F80187A7	60"	36 x 36"	5"	51"	83"	138"	1,400
F80178A8	60"	48 x 51"	5"	66"	91"	146"	1,668
F80175A5	72"	36 x 36"	5"	51"	92"	159"	1,675
F80172A2	72"	48 x 51"	5"	66"	98"	167"	1,950

### 4,000 LB Capacity

Model No.	Dump Height	Chute L x W	Chute Reach	Frame Width	Horizontal Clearance	Overhead Clearance	Weight (lbs)
F80192A2	36"	36 x 36"	12.5"	51"	72"	111"	1,500
F80183A3	36"	48 x 51"	12.5"	66"	81"	119"	1,800
F80189A9	48"	36 x 36"	10"	51"	79"	127"	1,600
F80180A0	48"	48 x 51"	10"	66"	87"	135"	2,100
F80186A6	60"	36 x 36"	5"	51"	83"	138"	1,750
F80177A7	60"	48 x 51"	5"	66"	91"	146"	2,000
F80174A4*	72"	36 x 36"	5"	51"	83"	149"	2,000
F80171A1*	72"	48 x 51"	5"	66"	91"	158"	2,275

### 6,000 LB Capacity

Model No.	Dump Height	Chute L x W	Chute Reach	Frame Width	Horizontal Clearance	Overhead Clearance	Weight (lbs)
F80191A1	36"	36 x 36"	12.5"	51"	72"	111"	1,500
F80182A2	36"	48 x 51"	12.5"	66"	81"	119"	1,825
F80188A8	48"	36 x 36"	10"	51"	79"	127"	1,600
F80179A9	48"	48 x 51"	10"	66"	87"	135"	2,100
F80185A5	60"	36 x 36"	5"	51"	83"	138"	1,750
F80176A6	60"	48 x 51"	5"	66"	91"	146"	2,000
F80173A3*	72"	36 x 36"	5"	51"	83"	149"	2,000
F80170A0*	72"	48 x 51"	5"	66"	91"	158"	2,275

\*72" dump height models in 4000-lb and 6000-lb capacities have chute elevated 12" off the floor. Fork lift required for loading.

# Chip Trucks

EZY-Rol™ brand Chip Trucks are manufactured to handle bulky loads with stability and ease. The tapered end style of these uniquely designed units make them adaptable to a variety of material handling needs.

Model	Description	Dimensions	Tires	Capacity	Product Weight
F85142A5	4-Wheel Dual Taper Chip Truck	39" H x 68" L x 30" W	8" Mold-On	14.3 cu. ft. / 2000 lbs.	198 lbs
F85161A1	4-Wheel Dual Taper Chip Truck	39" H x 68" L x 36" W	8" Mold-On	17.2 cu. ft. / 2000 lbs.	205 lbs
F85096A1	3-Wheel Dual Taper Chip Truck	39" H x 68" L x 24" W	8" Mold-On	11.2 cu. ft. / 1500 lbs.	164 lbs
F85056A9	3-Wheel Single Taper Chip Truck	39" H x 48" L x 24" W	8" Mold-On	9 cu. ft. / 1000 lbs.	146 lbs

4-Wheel Dual Tapered Chip Trucks are constructed of 14-ga. steel with leak-proof solid welds on the seams for long-lasting, dependable service. The running gear consists of two fixed casters reinforced by steel tubing and two swivel steering casters. Tapered ends allow chip truck to adapt to virtually any material handling situation, and provide for safe and easy loading and unloading. Hemmed lip around the top edge of the truck provides reinforcement with bulky loads, and steel handles aid in maneuvering trucks. Rolls on 8" molded-on solid casters.

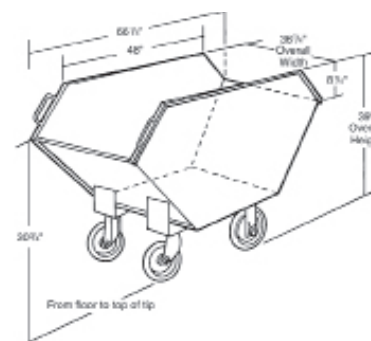

**F85142A5**  
2 Fixed Casters -  
2 Rear Swivel Casters

3-Wheel Dual Tapered Chip Trucks roll on two axle-mounted wheels with ball bearings and one rear swivel caster with roller bearings. Truck is constructed of 14-ga. steel with leak-proof solid welds on the seams. Tapered ends allow chip truck to adapt to virtually any material handling situation, and provide for safe and easy loading and unloading. Hemmed lip around the top edge of the truck provides reinforcement with bulky loads, and steel handles aid in maneuvering trucks. Rolls on 8" molded-on solid casters.

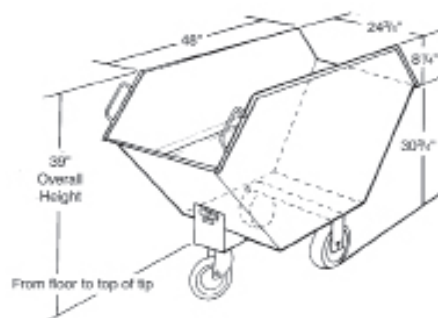

**F85096A1**  
2 Fixed Casters -  
1 Rear Swivel Caster

3-Wheel Tapered Chip Trucks roll on two axle-mounted wheels with ball bearings and one swivel caster with roller bearings mounted at either the tapered end of truck or flat end. Truck is constructed of 14-ga. steel with leak-proof solid welds on the seams. Tapered ends allow chip truck to adapt to virtually any material handling situation, and provide for safe and easy loading and unloading. Hemmed lip around the top edge of the truck provides reinforcement with bulky loads, and steel handles aid in maneuvering trucks. Rolls on 8" molded-on solid casters.

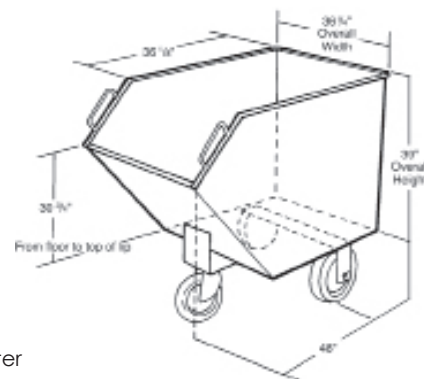

**F85056A9**  
2 Fixed Casters -  
1 Rear Swivel Caster



# Drum Dumpers

## SINGLE STAGE, HYDRAULIC

Valley Craft's Single Stage Drum Dumpers are available in Stationary or Portable models, 1,000-lb. or 1,500-lb. capacities, with dump heights ranging from 36" to 60" with a 45-degree dumping angle. Valley Craft's drum dumpers include a NEMA12 power up/gravity down power unit with adjustable flow control to safely lower chute to its down position. The 1/60/110V power unit is equipped with a 1HP motor and a 1GPM pump. Drum dumpers feature an adjustable hold-down bar to accommodate various drum heights up to 43". Includes a hand pendant with magnetic back and durable coiled cord. Heavy gauge carbon steel construction has a durable powder coat finish in green.

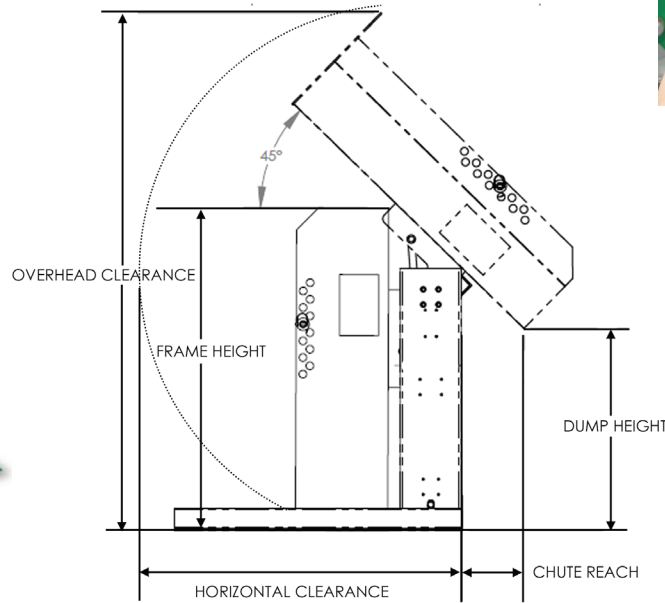

Hand pendant front view

Magnetic back of hand pendant

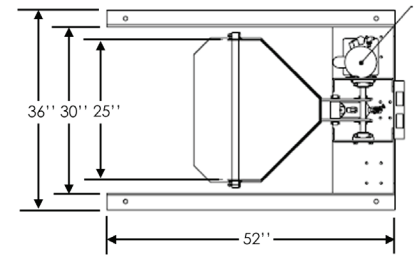

## Stationary

Load Capacity	1,500 lbs		
Part Number	F80163A3	F80161A1	F80159A9
Name	36" Low Level	48" Low Level	60" Low Level
Weight	660 lbs	690 lbs	720 lbs
Width	36"	36"	36"
Length	52"	52"	52"
Frame Height	58.5"	65.5"	72.5"
Dump Height	36"	48"	60"
Overhead Clearance	96.5"	112.5"	129.5"
Chute Reach	11"	9"	7"
Horizontal Clearance	60"	68"	76"
Cycle Time (Up Only)	25 sec	25 sec	25 sec

## Portable

Load Capacity	1,500 lbs		
Part Number	F80162A2	F80160A0	F80158A8
Name	36" Low Level	48" Low Level	60" Low Level
Weight	510 lbs	530 lbs	563 lbs
Width	36"	36"	36"
Length	52"	52"	52"
Frame Height	59.5"	66.5"	73.5"
Dump Height	37"	49"	61"
Overhead Clearance	97.5"	113.5"	130.5"
Chute Reach	11"	9"	7"
Horizontal Clearance	60"	68"	76"
Cycle Time (Up Only)	25 sec	25 sec	25 sec

# Drum Dumpers

## DUAL STAGE, HYDRAULIC

Dual Stage Drum Dumpers are available in Stationary or Portable models, with dump heights ranging from 72" to 120" with a 45-degree dumping angle. 1,500-lb load capacity. Chute rises vertically until arms meet pivot rollers, causing chute to rotate. Includes NEMA12 power up/gravity down power unit with adjustable flow control to safely lower chute to its down position. The 1/60/110V power unit is equipped with a 1HP motor and a 1GPM pump. Drum dumpers feature an adjustable hold-down bar to accommodate various drum heights up to 43". Includes a hand pendant with magnetic back and durable coiled cord. Heavy gauge carbon steel construction has a durable powder coat finish in green.

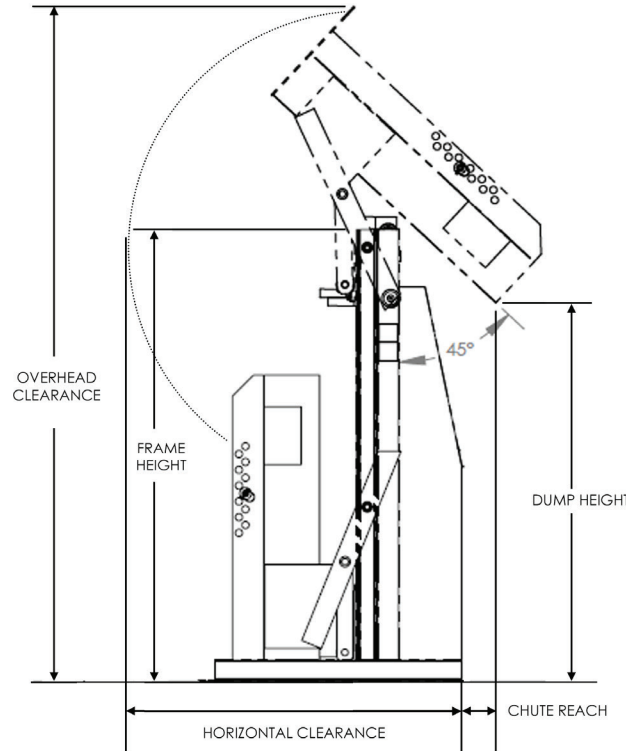

Hand pendant front view

Magnetic back of hand pendant

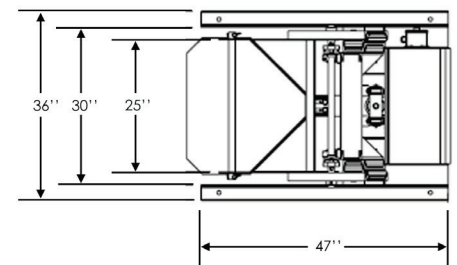

## Stationary

Load Capacity	1,500 lbs	
Part Number	F80157A7	F80155A5
Name	72" High level	84" High Level
Weight	1,125 lbs	1,160 lbs
Width	36"	36"
Length	47"	47"
Frame Height	86"	98"
Dump Height	72"	84"
Overhead Clearance	131"	143"
Chute Reach	6.5"	6.5"
Horizontal Clearance	66"	66"
Cycle Time (Up Only)	58 sec	68 sec

## Portable

Load Capacity	1,500 lbs	
Part Number	F80156A6	F80154A5
Name	72" High level	84" High Level
Weight	1,125 lbs	1,160 lbs
Width	36"	36"
Length	51"	51"
Frame Height	87"	99"
Dump Height	73"	85"
Overhead Clearance	132"	144"
Chute Reach	6.5"	6.5"
Horizontal Clearance	66"	66"
Cycle Time (Up Only)	58 sec	68 sec



Professional Grade Quality....Built to Last....Made in the U.S.A.

## Level Lift



The only forward dumping drum handler in the industry with a hand crank dump and no messy chains. Dumpers also incorporate a unique auto-drum leveling feature as drum is raised or lowered. This battery-powered unit has manual dump control with full 360-degree forward or reverse rotation, allowing operators to pour drum contents in a precise manner. Easy-to-load bonded rubber cradles handle 800-lb fully loaded or 500-lb half-full drums. Additional features include a heavy duty welded frame, step-down floor locks, and 8" Polyethylene wheels and 4" swivel casters. The maximum lift height is measured from floor to lowest point of a horizontal 55-gallon drum.



**F89759**  
72" Level Lift



Part Number	F89759
Name	72" Lift
Load Capacity	800 lbs
Weight	579 lbs
Width	41"
Length	68"
Height	59 - 72"
Lift Speed	3.4" / sec

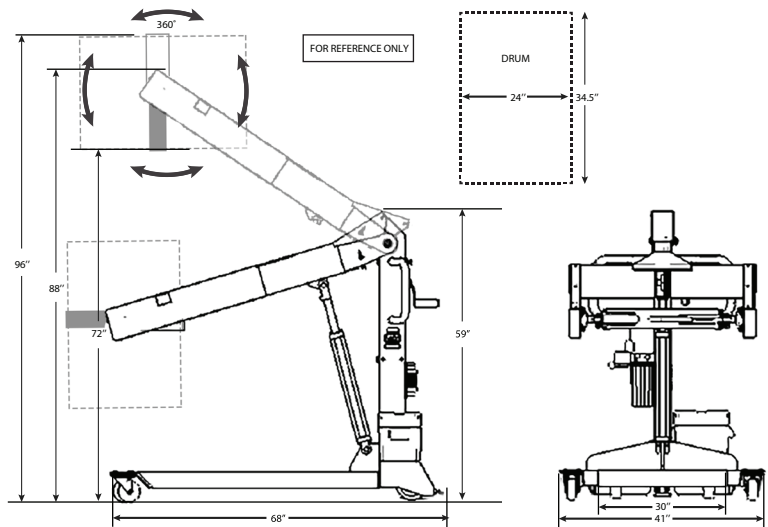

**F89758**  
96" Level Lift



Part Number	F89758
Name	96" Lift
Load Capacity	800 lbs
Weight	579
Width	44"
Length	84"
Height	59 - 96"
Lift Speed	3.4" / sec

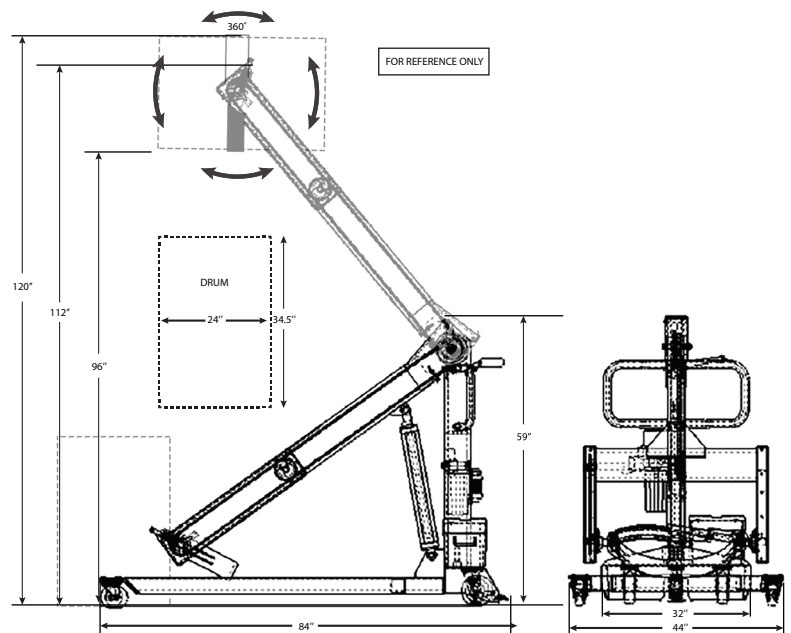



# Hydraulic Self Dumping System

Valley Craft's Hydraulic Fork Lift Dumper System is a two-piece material handling system designed to increase productivity around the warehouse. You can quickly reduce the number of fork lifts required to complete jobs around the warehouse when you introduce the Fork Lift Dumper system. When one hopper is filled, employees can easily roll it out of the way and replace it with an empty hopper, and production can continue uninterrupted. As the fork lift operator makes the rounds, it is quick and easy to connect, then move and dump the contents. The fork lift attachment and mobile hoppers (available in two sizes) are sold separately and offer a 2,000-lb load capacity. This lift truck powered attachment requires auxiliary valve control and hydraulic quick couplers on the lift truck. A secure latching system automatically locks hoppers to the attachment. The Mobile Hoppers are constructed of 14-gauge steel, feature watertight continuous welds, and roll easily on two fixed and two swivel 6" casters. All hoppers have tapered fronts to help initiate dumping. Custom hopper sizes are available within the 2,000 lbs. limitation of the attachment.

Model No.	Description	Load Capacity	Overall Dimensions (L x W x H)	Usable Fork Tube Size	Distance Between Forks	Product Weight
F89681	Forklift Attachment	2,000 lbs	40½" L x 41" W x 13" H	31½" L x 6½" W x 2½" H	27.5"	280 lbs
F89679	½ cubic yard Mobile Hopper	2,000 lbs	30" W x 46" L x 30" H	-	-	150 lbs
F89680	1 cubic yard Mobile Hopper	2,000 lbs	30" W x 53" L x 45" H	-	-	200 lbs



**F89681**  
Hydraulic Forklift Attachment

**F89680**  
Mobile Hopper

## 3 Steps to use the Hydraulic Self Dumping System:



**Step 1:** Connect the Fork Lift Attachment and secure into place.



**Step 2:** Roll Mobile Hoppers to Fork Lift Attachment and engage secure latching system.



**Step 3:** Transport Mobile Hopper to dumping location and empty. When finished, lower completely to floor. Release Mobile Hopper from Fork Lift Attachment by easily pulling on the attached cord.



# Casino Hand Trucks



Side view with casino slot machine



**F89699**  
Casino Truck

Valley Craft's Casino Hand Trucks include our unique hand brake system and provide a much safer and efficient way to move large loads. This heavy duty truck features a sliding frame (available in two sizes) that helps the operator to more easily break-over heavy loads. The frame-and-shoe assembly can slide downward as the truck is tilted back. Heavy duty, 12"x3½" pneumatic tires provide a cushioned ride. Two 6x2" rear, cushioned-rubber swivel wheels help prevent loads from tipping back, as well as providing ease of movement. Truck includes secure strapping attachment, and the ratchet securely tightens and locks the strap, securing the load. A simple quick release lever unlocks the strap. Unit adjusts vertically on a mounting bar and can be set at the most accurate point in relation to height load. 15' nylon strap included.

Model	Description	Dimensions (W x D x H)	Shoe Size (W x D)	Load Cap (lbs)	Prod Weight (lbs)
F89699	Casino Hand Truck	23" x 32" x 49¾"	23" x 8"	1000	85
F89206	Casino Hand Truck - Extended Frame	23" x 33" x 61½"	23" x 8"	1000	92

## Cylinder Hand Trucks

Spark-resistant aluminum Cylinder Trucks for safe, efficient handling of pressurized tanks. Choose the heavy duty single frame for cylinders 9" in diameter, or the multi-tank frame that fits over the regular box frame for use with most standard size cylinders. Balanced frames roll easily on 12" x 3½" fully-pneumatic tires and feature hand brakes for added safety. Multi-tank frame is available with and without brakes. 1" steel axle is enclosed in protective housing with sealed bearings. Trucks are constructed of 1.315" O.D. aluminum tubing with notched joints and solid welds. 600-lb. load capacity.

### Single Cylinder Aluminum Frame Models

Model	Dimensions	Shoe Size	Cylinder Size	Prod Wt
F81238A9	20"W x 16"D x 50"H with brakes	12½"W x 4"D Steel	9" diameter	41 lbs
F81303A9	23"W x 20"D x 50"H with brakes	16"W x 8"D Steel	14" diameter	47 lbs

**F81238A9**  
Single Cylinder  
model



### Two-Cylinder Aluminum Frame Models

Model	Dimensions	Shoe Size	Cylinder Size	Prod Wt
F86065A6	22¾"W x 25¾"D x 50"H with brakes	19"W x 10"D Aluminum	fits most standard	66 lbs
F86070A9	23"W x 26"D x 50"H - no brakes	19"W x 10"D Aluminum	fits most standard	62 lbs

**F86065A6**  
Two-Cylinder  
model



## Commercial Hand Trucks - Aluminum

Valley Craft's commercial line of hand trucks is built to handle heavy, cumbersome loads & crafted to last through years of rugged use. All models have a heavy-duty steel shoe, replaceable steel axles, and roll easily on premium pneumatic tires. Aluminum tubing construction is lightweight and easy to handle; all joints are form-fitted for maximum strength & durability. 600-lb load capacity.

Model	Description	Dimensions	Shoe Size	Product Weight
F81797A2	Trayless 12-pack Delivery Truck	19½"W x 17¼"D x 52"H	8" x 16"	38 lbs

- Twin loop handles for versatile maneuvering
- Extra-wide frame to handle bulky, trayless beverage packs
- Oversized skid rails protected by replaceable steel guards



**F81797A2**  
Trayless 12-pack Delivery Truck

### Flat Back Beverage Trucks

Model	Dimensions	Shoe Size	Fenders	Hand Brakes	Product Weight
F83937A9	20"W x 17½"D x 51½"H	8" x 16"	-	-	34 lbs
F83947A7	20"W x 19¾"D x 51½"H	10" x 16"	-	-	34 lbs
F84009A0	18½"W x 19½"D x 51½"H	10" x 16"	-	Yes	41 lbs
F83941A3	21"W x 17½"D x 51½"H	8" x 16"	Yes	-	40 lbs
F83944A0	21"W x 19½"D x 51½"H	10" x 16"	Yes	-	42 lbs
F84008A1	20"W x 19½"D x 50½"H	10" x 16"	Yes	Yes	45 lbs

- Standard twin handles
- Tapered truck frame, available with Flat or Curved back
- All-welded, aluminum tubing construction for lightweight and easy handling
- 600-lb load capacity
- Heavy-duty steel shoes
- Optional hand brakes on some models, to provide control and safe transport on ramps, stairs, and over curbsides
- Typical capacity is 10 cases, two half barrels, or one CO<sub>2</sub> cylinder
- Rolls on Premium Pneumatic tires
- Replaceable steel axle

### Curved Back Beverage Trucks

Model	Dimensions	Shoe Size	Hand Brakes	Product Weight
F83880A6	20"W x 17¾"D x 51½"H	8" x 16"	no	32 lbs
F83881A5	20"W x 19¾"D x 51½"H	10" x 16"	no	33 lbs

**F83881A5**  
Curved Back Beverage Truck



**F83947A7**  
Flat Back Beverage Truck



HEAVY DUTY

Drum Trucks - Powered



Heavy Duty Powered Drum Trucks are designed for safe navigation of heavy loads in tight quarters, on inclines, or uneven terrain. Perfect for places where traditional powered machines will not work due to space restriction. Features include a rugged 24V DC differential drive motor, full function forward and reverse travel with reverse audible warning, built-in 18 AH battery with charging/monitor system, and exclusive easy grip hand brake. Shoes adjust to handle 30- and 55-gal. drums up to 800 lbs. Includes our standard spring-loaded drum chime hook - four optional chime hooks available. Speed settings include 1.4MPH (walk) or 0.5MPH (crawl) speeds. Approved for use on a 5° incline.



**F89503**  
Powered Drum Truck  
Solid Rubber

Solid Rubber Wheels

Part Number	F89503
Name	Powered Drum Truck w/Solid Rubber Wheels
Load Capacity	800 lbs
Weight	150 lbs
Width	24½"
Depth	20½"
Height	60"
Chime Hook	Standard



**Solid Rubber Tire**  
10 x 2½"  
Standard tire on  
all drum trucks.



**F89484**  
Powered Drum Truck  
Pneumatic

Pneumatic Wheels

Part Number	F89484
Name	Powered Drum Truck w/Pneumatic Wheels
Load Capacity	800 lbs
Weight	160 lbs
Width	26"
Depth	20½"
Height	62"
Chime Hook	Standard



**Pneumatic Tire**  
12 x 3½"  
Disassembles to  
replace tire and  
tube.

Drum Truck Chime Hooks

All models come with the standard chime hook, unless otherwise specified. Please indicate which chime hook you would prefer by adding the corresponding letter suffix to the drum truck part number.

Function	S	F P S	F	F P S	P
Part Number	Comes Standard	"L" as suffix	"F" as suffix	"C" as suffix	"P" as suffix
Name	Standard Chime Hook	Locking Cover Chime Hook	Fiber Drum Chime Hook	Cable Hoop Chime Hook	Plastic Drum Chime Hook
Load Capacity	800 lbs	800 lbs	800 lbs	800 lbs	800 lbs
Weight	8 lbs	8 lbs	8 lbs	8 lbs	8 lbs
Features	Automatically engages drum. Comes standard on automatic drum trucks.	Handles drums with Locking cover. May be used on aluminum truck and handles standard drums.	Reaches an extra inch to hook rim of fiber drums. Also handles standard drums.	Hook Cable on standard chime hook wraps around drums without a chime.	Hook Drops over bung hole projection on standard drums. May be used on aluminum truck.



# Drum Trucks - Aluminum S P F

Spark resistant aluminum framed EZY-Rol™ Automatic Drum Trucks are the answer to safe and effective manual transport and handling of drum inventories. All drum trucks feature Valley Craft's exclusive EZY-Rol™ design and spring-loaded standard chime hook so the operator never has to touch the drum. Choice of 2-wheel or 4-wheel models. Shoes adjust to handle 30- and 55-gal. drums up to 1,000 lbs. Available with optional hand brakes for added safety. Replaceable wheels, shoes and axles available. Four additional chime hooks and three wheel options available.



**F81500A0**  
Aluminum  
Pneumatic

## 2-Wheel Drum Trucks

Brakes	With Brakes		No Brakes	
Part Number	F81925A7	F82050A2	F81500A0	F81625A0
Name	Aluminum Pneumatic w/ Brakes	Aluminum Solid Rubber w/ Brakes	Aluminum Pneumatic	Aluminum Solid Rubber
Load Capacity	1,000 lbs	1,000 lbs	1,000 lbs	1,000 lbs
Weight	46 lbs	55 lbs	40 lbs	50 lbs
Width	26"	25"	26"	25"
Depth	18"	18"	18"	18"
Height	52"	52"	52"	52"
Chime Hook	Standard	Standard	Standard	Standard



**F83210A7**  
Aluminum Solid  
Rubber with  
Brakes

## 4-Wheel Drum Trucks

Brakes	With Brakes		No Brakes		
Part Number	F82960A1	F83210A7	F82175A2	F82425A0	F82645A4
Name	Aluminum Pneumatic w/ Brakes	Aluminum Solid Rubber w/ Brakes	Aluminum Pneumatic	Aluminum Solid Rubber	Aluminum Mold-On
Load Capacity	1,000 lbs	1,000 lbs	1,000 lbs	1,000 lbs	1,000 lbs
Weight	52 lbs	51 lbs	45 lbs	46 lbs	45 lbs
Width	26"	25"	25½"	25"	25"
Depth	20¾"	19¾"	20¾"	20"	20"
Height	58.9"	58.9"	58.9"	58.9"	58.9"
Chime Hook	Standard	Standard	Standard	Standard	Standard

## Drum Truck Chime Hooks

All models come with the standard chime hook, unless otherwise specified. Please indicate which chime hook you would prefer by adding the corresponding letter suffix to the drum truck part number.

Function	<span>S</span>	<span>F</span> <span>P</span> <span>S</span>	<span>F</span>	<span>F</span> <span>P</span> <span>S</span>	<span>P</span>
Part Number	Comes Standard	"L" as suffix	"F" as suffix	"C" as suffix	"P" as suffix
Name	Standard Chime Hook	Locking Cover Chime Hook	Fiber Drum Chime Hook	Cable Hoop Chime Hook	Plastic Drum Chime Hook
Load Capacity	800 lbs	800 lbs	800 lbs	800 lbs	800 lbs
Weight	8 lbs	8 lbs	8 lbs	8 lbs	8 lbs
Features	Automatically engages drum. Comes standard on automatic drum trucks.	Handles drums with Locking cover. May be used on aluminum truck and handles standard drums.	Reaches an extra inch to hook rim of fiber drums. Also handles standard drums.	Hook Cable on standard chime hook wraps around drums without a chime.	Hook Drops over bung hole projection on standard drums. May be used on aluminum truck.



Pneumatic Tire  
12 x 3½"  
Disassembles to  
replace tire and  
tube.



Solid Rubber Tire  
10 x 2½"  
Standard tire on  
all drum trucks.



Molded-On Tire  
10 x 2½"  
Brakes not  
available with this  
wheel.



Our unique braking system features a simple hand lever that operates brake bands equally on both load-carrying wheels, providing a safer and more efficient way to move heavy loads. These brakes give the operator complete control on ramps and inclines, and keep the wheels stationary while breaking over loads. Not available with molded-on solid rubber tires.

# Drum Trucks - Steel S P F

Steel framed EZY-Rol™ Automatic Drum Trucks are the answer to safe and effective manual transport and handling of drum inventories. All drum trucks feature Valley Craft's exclusive EZY-Rol™ design and spring-loaded standard chime hook so the operator never has to touch the drum. Choice of 2-wheel or 4-wheel models. Shoes adjust to handle 30- and 55-gal. drums up to 1,000 lbs. Available with optional hand brakes for added safety. Replaceable wheels, shoes and axles available. Four additional chime hooks and three wheel options available.



**F81735A7**  
Steel Solid Rubber

## 2-Wheel Drum Trucks

Brakes	With Brakes		No Brakes	
Part Number	F82025A4	F82150A1	F81600A9	F81735A7
Name	Steel Pneumatic w/Brakes	Steel Solid Rubber w/ Brakes	Steel Pneumatic	Steel Solid Rubber
Load Capacity	1,000 lbs	1,000 lbs	1,000 lbs	1,000 lbs
Weight	78 lbs	78 lbs	67 lbs	70 lbs
Width	25½"	25"	25½"	25"
Depth	19¾"	19¾"	19¾"	19¾"
Height	52"	52"	52"	52"
Chime Hook	Standard	Standard	Standard	Standard



**F82895A1**  
Steel Solid Rubber

## 4-Wheel Drum Trucks

Brakes	With Brakes		No Brakes		
Part Number	F83160A7	F83450A6	F82375A0	F82895A1	F82845A2
Name	Steel Pneumatic w/Brakes	Steel Solid Rubber w/ Brakes	Steel Pneumatic	Steel Solid Rubber	Steel Mold-On
Load Capacity	1,000 lbs	1,000 lbs	1,000 lbs	1,000 lbs	1,000 lbs
Weight	84 lbs	80 lbs	75 lbs	73 lbs	82 lbs
Width	25½"	25"	25½"	25"	25"
Depth	21"	20"	20¾"	20"	20"
Height	58.9"	58.9"	58.9"	58.9"	58.9"
Chime Hook	Standard	Standard	Standard	Standard	Standard

## Drum Truck Chime Hooks

All models come with the standard chime hook, unless otherwise specified. Please indicate which chime hook you would prefer by adding the corresponding letter suffix to the drum truck part number.

Function	<span>S</span>	<span>L</span> <span>F</span> <span>P</span> <span>S</span>	<span>F</span>	<span>C</span> <span>F</span> <span>P</span> <span>S</span>	<span>P</span>
Part Number	Comes Standard	"L" as suffix	"F" as suffix	"C" as suffix	"P" as suffix
Name	Standard Chime Hook	Locking Cover Chime Hook	Fiber Drum Chime Hook	Cable Hoop Chime Hook	Plastic Drum Chime Hook
Load Capacity	800 lbs	800 lbs	800 lbs	800 lbs	800 lbs
Weight	8 lbs	8 lbs	8 lbs	8 lbs	8 lbs
Features	Automatically engages drum. Comes standard on automatic drum trucks.	Handles drums with Locking cover. May be used on aluminum truck and handles standard drums.	Reaches an extra inch to hook rim of fiber drums. Also handles standard drums.	Hook Cable on standard chime hook wraps around drums without a chime.	Hook Drops over bung hole projection on standard drums. May be used on aluminum truck.



Pneumatic Tire  
12 x 3½"  
Disassembles to replace tire and tube.



Solid Rubber Tire  
10 x 2½"  
Standard tire on all drum trucks.



Molded-On Tire  
10 x 2½"  
Brakes not available with this wheel.



Our unique braking system features a simple hand lever that operates brake bands equally on both load-carrying wheels, providing a safer and more efficient way to move heavy loads. These brakes give the operator complete control on ramps and inclines, and keep the wheels stationary while breaking over loads. Not available with molded-on solid rubber tires.



# HVAC Hand Trucks

The HVAC Truck makes handling those large bulky heating and cooling units safer and easier with an ergonomic hand truck designed for efficiency and built for durability. The 4-wheel design with loop handle makes transporting oversized loads a much more efficient task by increasing productivity and decreasing the chance for damage.



The forks measure 24" and allows for safe loading and unloading of large heating and air conditioning units, or any other large palletized load, while over-sized fenders stabilize the load. The foot-activated trip pedal locks and unlocks fork position. Simply slide the angled truck forks under the load, tilt forward to lock forks in place and break-over the load. Forks lock against the frame for compact storage.

**F80233U5**  
Big Blue  
HVAC Truck



**F80234B6** Strap  
Attachment

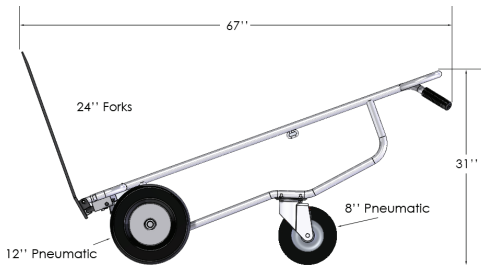
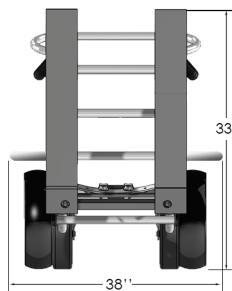

Model No.	Description	Dimensions	Shoe Length	Load Cap. (lbs)	Product Weight (lbs)
F80233U5	Big Blue HVAC Truck	60½"H x 26"W x 21½"D	24"	600	95
F80234B6	Strapping Attachment	-	-	-	4

# Industrial Hand Trucks



**F85261A0**  
Flat Forks



**F85264A7**  
Transmission Forks

Valley Craft's Industrial Hand Truck makes transferring heavy transmission cases, engines, and cumbersome parts bins a safe and efficient task. Add safety to your workplace and incorporate this heavy duty industrial hand truck within your distribution center, on your semis, and inside your garage area. The two fork styles are interchangeable - each style can be ordered as an optional accessory. 800-lb maximum load capacity.

Model	Description	Tires	Dimensions	Prod Wt (lbs)
F86182A4FF	Industrial Hand Truck with Flat Forks	Mold-On	25"W x 25¾"D x 52"H	98
F86182A4TF	Industrial Hand Truck with Transmission Forks	Mold-On	25"W x 30½"D x 52"H	102
F85882A3FF	Industrial Hand Truck with Flat Forks	Never Flat	26"W x 25¾"D x 52"H	77
F85882A3TF	Industrial Hand Truck with Transmission Forks	Never Flat	26"W x 30½"D x 52"H	79
F85261A0	Flat Forks (set, sold separate as Accessory)	-	4"W x 18¾"D x 12¼"H	25
F85264A7	Transmission Forks (set, sold separate as Accessory)	-	2"W x 23"D x 12¼"H	27

**F86182A4TF**  
Mold-On Tires



## Nursery Trucks

Valley Craft's Nursery Hand Trucks are constructed to meet special needs within the nursery industry. The heavy-duty construction of each piece was designed to withstand punishment from dirt, water, and usage.



**F86088A9**  
EZY-Rol™ Heavy  
Duty Nursery Hand  
Truck

Large hand truck designed for moving balled and potted trees.

- Constructed of 1¼" x 12-gauge steel tubing
- High position skid rails provide extra strength and support if truck is dropped
- Steel tow hook for safe and easy handling
- Shoe size: 23" W x 5" D
- Large 16" x 8" Pneumatic tires provide maximum cushioning and easy handling over rough or smooth terrain
- Sturdy 1" cold-roll steel axle is encased in steel housing for longer truck life
- Green powder coat finish for added durability
- 1500 pounds load capacity

### Nursery Hand Trucks

Model	Description	Dimensions	Wheel Size	Load Capacity	Product Weight
F86088A9	EZY-Rol™ Heavy Duty Hand Truck	39" W x 23" D x 63½" H	16" x 8"	1500 lbs	90 lbs
F86083A4	Heavy Duty Containerized Hand Truck	39" W x 31" D x 63½" H	16" x 8"	1000 lbs	105 lbs

Large nose hand truck designed for movement of containerized plants.

- Constructed of 1¼" x 12-gauge steel tubing
- Shoe is 22" wide x 15¼" deep, ideal for handling potted plants and assorted containers
- High position skid rails provide extra strength and support if truck is dropped
- Steel tow hook for safe and easy handling
- Shoe size: 22" W x 15" D
- Large 16" x 8" Pneumatic tires provide maximum cushioning and easy handling over rough or smooth terrain
- Sturdy 1" cold-roll steel axle is encased in steel housing for longer truck life
- Green powder coat finish for added durability
- 1500 pounds load capacity

**F86083A4**  
Heavy Duty  
Containerized  
Nursery Hand Truck



## Pallet Trucks

### FOUR WHEEL

4-Wheel Deep Frame Bag & Box Hand Trucks feature a set of 6" swivel casters mounted on extended skid rails, to better assist the operator in balancing the load. The rear wheels fix the angle at which the frame is balanced, so these trucks are recommended for use on flat surfaces or inclines of no more than 10 degrees and with loads that are not extremely deep in relation to the height. Choose from 14-gauge, 1½" O.D. steel tubing frame with form-fitted joints, or 1½" spark-resistant aluminum frame. Some models offer hand brakes for added safety. 1000-lb. load capacity.

### 4-Wheel, Deep Frame, Steel Bag & Box Models with shoe

Model	Frame H x W	Shoe	Tires	Product Wt (lbs)
F84808A3	54 x 25¾"	10x19"	Solid Rubber	95

### 4-Wheel, Deep Frame, Aluminum Bag & Box Models with shoe

Model	Frame H x W	Shoe	Tires	Product Wt (lbs)
F84800A1	54 x 26"	10x19"	Solid Rubber	80



**F84808A3**  
4-Wheel Steel Deep Frame with Solid Rubber Tires

2-Wheel Deep Frame Pallet Hand Trucks have a 6" longer frame and 19" skid rails to prevent truck from falling back on operator. Features 14-ga., 1½" O.D. steel tubing with form-fitted joints and solid welds, or 1½" spark-resistant aluminum tubing. Some models offer hand brakes for added safety. 1000-lb. load capacity.

### 2-Wheel, Deep Frame, Steel Models with forks

Model	Frame H x W	Shoe	Tires	Product Wt (lbs)
F84907A3	60 x 25¾"	13¾"	Pneumatic	84
F84910A8	60 x 25¾"	13¾"	Solid Rubber	81

### 4-Wheel, Deep Frame, Steel Model with forks

Model	Frame H x W	Shoe	Tires	Product Wt (lbs)
F84813A6	54 x 25¾"	13¾"	Solid Rubber	105

### 2-Wheel, Deep Frame, Aluminum Models with forks

Model	Frame H x W	Shoe	Tires	Product Wt (lbs)
F84906A4	60 x 26"	13¾"	Pneumatic	70
F84908A2	60 x 26"	13¾"	Solid Rubber	69



**F84907A3**  
2-Wheel Steel Deep Frame with Pneumatic Tires

# Pallet Trucks

## TWO WHEEL

EZY-Tilt® handling trucks makes material handling easier than ever before. The EZY-Tilt® design reduces handling of cargo and eliminates damage. Simply slide the angled truck forks under the load, tilt forward to lock forks in place and break-over the load.

EZY-Tilt® Pallet Trucks are constructed of rugged 14-gauge, 1½" O.D. steel tubing with form-fitted joints and solid welds, with reinforcement intentionally placed at the points of greatest stress. Steel, double-forked shoe locks into position automatically and is easily released by tripping a foot lever. Forks are available in two standard lengths. 1" steel axle is encased in a protective housing. Available with optional hand brakes. Replaceable parts include shoes, axles, and tires for easy service and longer life. Optional aluminum frame is lighter than its steel counterpart, but just as reliable. Constructed of 1½" spark-resistant tubing, aluminum is recommended for services when the truck must be transported, and for use around corrosive materials. 1000-lb. capacity.

### Standard 2-Wheel, Steel Frame

Model	Frame H x W	Shoe	Tires
F84738A8	48 x 14½"	13¾"	Pneumatic
F84879A7	48 x 14½"	13¾"	Pneumatic with Brakes
F84776A1	48 x 14½"	13¾"	Solid Rubber
F84883A1	48 x 14½"	13¾"	Solid Rubber with Brakes
F84793A0	48 x 14½"	13¾"	Mold-On Rubber

### Standard 2-Wheel, Aluminum Frame

Model	Frame H x W	Shoe	Tires
F84727A1	48 x 14½"	13¾"	Pneumatic
F84877A9	48 x 14½"	13¾"	Pneumatic with Brakes
F84753A8	48 x 14½"	13¾"	Solid Rubber
F84892A0	48 x 14½"	13¾"	Solid Rubber with Brakes
F84752A9	48 x 14½"	13¾"	Mold-On Rubber

#### F84738A8

2-Wheel Steel with Pneumatic Tires



#### F84753A8

2-Wheel Aluminum with Solid Rubber Tires



## Plastic Pallets

Plastic Pallets designed especially for EZY-Tilt® Pallet Trucks and come in two different sizes. Each pallet weighs one pound and has a stringer height of 1½" to meet your various handling needs. Pallets are black in color and can easily handle up to 800 lbs.

Model No.	Description	Stringer Height	Load Capacity
Z84976A3	12 x 24" Plastic Pallet (sold by each)	1 ½"	800 lbs
F89510	12 x 24" Plastic Pallet (Pack of 15 each)	1 ½"	800 lbs
Z84978A1	15 x 24" Plastic Pallet (sold by each)	1 ½"	800 lbs
F89509	15 x 24" Plastic Pallet (Pack of 15 each)	1 ½"	800 lbs

#### Z84976A3

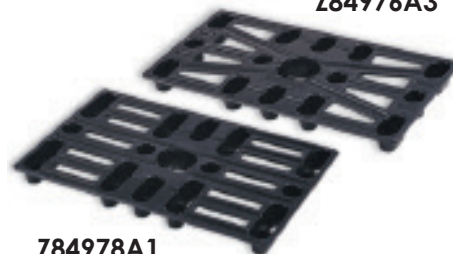

#### Z84978A1



Professional Grade Quality....Built to Last....Made in the U.S.A.

# Quad-Steer Trailers

Valley Craft's Pre-configured Trailers make selecting the right style easy. All Quad-Steer Trailers accurately track around corners with the smallest footprint and virtually no drift - some of the most precise tracking trailers in the industry.

- Heavy duty load capacity, 2,000 - 6,000 lbs
- 14-gauge steel deck
- 4-Wheel Precision Track Quad steering
- Powder coat finish in green
- Trailers link together to form a train
- Tightest turn radius in the industry
- Haul heavy loads safely
- Other combinations of deck size, capacity, wheels, & hitch groups are available upon request



## Wheel Styles

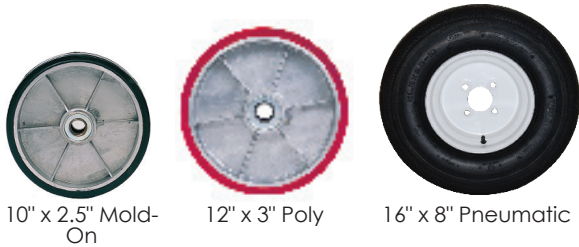

10" x 2.5" Mold-On

12" x 3" Poly

16" x 8" Pneumatic

## Hitch Styles



Pin & Clevis Tongue and Hitch Group

Ring & Pintle Tongue and Hitch Group

Model	Load Capacity	Deck Size	Wheel Style	Hitch Style	Height	Weight
F89752	2,000 lbs	36" W x 60" L	16" Pneumatic Wheels	Pin & Clevis	19.2"	270 lbs
F83984	2,000 lbs	36" W x 72" L	16" Pneumatic Wheels	Pin & Clevis	19.2"	284 lbs
F83980	2,000 lbs	48" W x 96" L	10" Molded On Wheels	Pin & Clevis	16.2"	377 lbs
F89750	2,000 lbs	48" W x 96" L	12" Poly Wheels	Pin & Clevis	19.5"	382 lbs
F83978	2,000 lbs	48" W x 96" L	16" Pneumatic Wheels	Pin & Clevis	19.2"	404 lbs
F89749	4,000 lbs	48" W x 96" L	12" Poly Wheels	Pin & Clevis	19.5"	492 lbs
F83991	4,000 lbs	48" W x 96" L	12" Poly Wheels	Ring & Pintle	19.5"	524 lbs
F83993	4,000 lbs	48" W x 96" L	16" Pneumatic Wheels	Ring & Pintle	21.5"	540 lbs
F83995	6,000 lbs	48" W x 96" L	12" Poly Wheels	Ring & Pintle	19.5"	607 lbs
F83997	6,000 lbs	48" W x 96" L	20" Pneumatic Wheels	Ring & Pintle	23.5"	681 lbs

## Industrial Desks



### Model F85827A0

This open base mobile Industrial Desk is all-welded and features an ergonomically-designed sloped table-top for safety and comfort.

- Sliding drawer with cylinder lock
- 100 lbs drawer capacity
- 3" rubber swivel casters.
- Gray powder coat finish
- 23" W x 20" D x 51" H
- Overall 400 lb total capacity
- Product weight: 77 lbs



### Model F85829A8

This closed base mobile Industrial Desk features an individually-locking compartment for added security.

- All-welded, steel construction
- Two locking drawers, 100 lbs capacity each
- 5" rubber swivel casters
- Lockable compartments
- Gray powder coat finish
- 23" W x 20" D x 51" H
- Overall 1000 lbs total capacity
- Product weight: 145 lbs



## Workbench Cabinets

Take your workstation with you with a Vari-Tuff Mobile Cabinet. Store and transport your workstation materials in these cabinets for quick and easy access to tools and supplies. A convenient combination of storage options includes units with shelving only, drawers only and units with both drawers and shelving.



**F83892A2**

### Models F83892A2 - F83893A1

Bin Workbench Cabinets offer a variety of mobile storage options, including drawers, shelving, and door bins.

- 5" rubber casters
- Door features full-length piano hinge and single-point locking handle
- Individual locks on drawers
- Non-slip black rubber top mat
- 3" high backstop
- Handles up to 800 lbs.
- Powder coat finish in Red
- **F83892A2** measures 36"W x 21"D x 35"H; includes (12) XS bins
  - Product Weight: 173 lbs, Shipping Weight: 213 lbs
- **F83893A1** measures 46"W x 21"D x 35"H; includes (24) XS bins
  - Product Weight: 193 lbs, Shipping Weight: 232 lbs



**F84917A1**

### Models F84917A1 - F84918A0 - F84919A9

Bin Workbench Cabinets keep parts organized and contained, while offering complete security. Handles up to 800 lbs.

- 3-point locking handle
- 5" rubber casters
- 1½"-high rim on back and both sides of top workspace
- Gray powder coat finish
- **F84917A1** measures 36"W x 22"D x 36½"H; includes (12) SM, (4) M, (2) XL bins
  - Product Weight: 192 lbs, Shipping Weight: 230 lbs
- **F84918A0** measures 36"W x 22"D x 36½"H; includes (12) M, (8) L bins
  - Product Weight: 189 lbs, Shipping Weight: 228 lbs
- **F84919A9** measures 36"W x 22"D x 36½"H; includes bin brackets only
  - Product Weight: 165 lbs, Shipping Weight: 205 lbs



### Model F81843A6

This all-welded, Industrial Workbench Cabinet adds a little extra space and convenience while offering total security.

- Measures 23"W x 20"D x 34" H
- Four locking drawers
- Like-keyed cylinder locks
- Drawers roll on ball bearing slides
- ½" back and side stops
- (2) swivel and (2) rigid 5" casters
- Handles up to 800 lbs.
- Gray powder coat finish
- Drawers measure: 20"W x 19¾" D x 5" H
- Product Weight: 133 lbs - Shipping Weight: 173 lbs

## Workbench Cabinets



### Model F81842A7

All-welded, Industrial Workbench utility cabinet features two locking drawers and a small bottom compartment to add versatility to your work environment.

- Measures 23"W x 20"D x 34" H
- Like-keyed cylinder locks
- ½" high back and side stops
- (2) swivel and (2) rigid 5" casters
- Handles up to 800 lbs.
- Gray powder coat finish
- Drawers measure: 20" W x 19¾" D x 5" H
- Product Weight: 116 lbs - Shipping Weight: 156 lbs



**F81834A7**

### Models F81834A7 - F81835A6

Compartment variety of this Industrial Workbench cabinet makes this one of the most versatile tool and supply mobile carts available.

- Four locking drawers
- Side compartment with stationary center shelf
- Door features full-length piano hinge and single-point locking handle
- (2) swivel and (2) rigid 5" rubber casters
- 3" high backstop
- Handles up to 800 lbs.
- Gray powder coat finish
- Drawers measure 20" W x 19¾" D x 5" H
- **F81834A7** measures 46"W x 21"D x 34" H - Product Weight: 181 lbs, Ship Weight: 212 lbs
- **F81835A6** measures 36"W x 21"D x 34" H, no center shelf - Product Wt: 159 lbs, Ship Wt: 196 lbs



**F81837A4**

### Models F81837A4 - F81838A3

This Industrial shelf cabinet is perfect for large and small tools alike. Partitioned compartment keeps items neatly organized.

- Single-point locking handle
- (2) swivel and (2) rigid 5" rubber casters
- 3" high backstop
- Handles up to 800 lbs.
- Gray powder coat finish
- **F81837A4** measures 46"W x 21"D x 34" H - Product Weight: 143 lbs, Ship Weight: 183 lbs
- **F81838A3** measures 36"W x 21"D x 34" H, includes single full-length center shelf - Product Weight: 119 lbs, Ship Weight: 152 lbs



# Deluxe Workbench Cabinets



**F89609RB**  
24" 3-3-6-6-6" Drawer Configuration, shown in Black/Red



**F89606BS**  
24" 3-6-6-9" Drawer Configuration, shown in Black/Silver



**F89606RB**  
24" 3-6-6-9" Drawer Configuration, shown in Black/Red, with Louver Back Panel option installed

## 24" Models

Model		Description	Drawer Heights			Weight (lbs)
Black/Red	Black/Silver		3"	6"	9"	
F89611RB	F89611BS	1 door	-	-	-	94
F89606RB	F89606BS	4 drawers (3,6,6,9)	1	2	1	125
F89609RB	F89609BS	5 drawers (3,3,6,6,6)	2	3	-	132

## Available Colors



Black / Red    Black / Silver

## Accessories



F89371BK

LOUVER BACK PANEL



F89392BK

PEGBOARD BACK PANEL



F89600

BUTCHER BLOCK TOP



F89598

NON-SKID RUBBER TOP



F89597

RUBBER MAT DRAWER INSERT

### COMPARTMENT DRAWER DIVIDERS

	F80132A5	16 compartment
	F80131A4	12 compartment
	F80130A3	8 compartment

### HANGING & STACKABLE BINS

	<b>XS</b> 5½" L x 4⅞" W x 3" H <b>Z80419A7</b> (Case of 24)
	<b>S</b> 7½" L x 4⅞" W x 3" H <b>Z80421A5</b> (Case of 24)
	<b>M</b> 11" L x 5½" W x 5" H <b>Z80422A4</b> (Case of 12)
	<b>L</b> 14¾" L x 8¼" W x 7" H <b>Z80424A2</b> (Case of 12)
	<b>XL</b> 14¾" L x 16½" W x 7" H <b>Z80426A0</b> (Case of 6)

- Dimensions: 24" W x 21"D x 36"H
- Flush front drawers and doors
- Single point locking mechanism
- Removable push handle that can be mounted on either left or right side
- Textured powder coat finish, available in 2 color combinations
- Rolls smoothly on (4) 6" casters: 2 locking swivel, 2 rigid
- Drawers offer 100 lbs load capacity and heavy duty ball bearing glides
- Door compartment includes one shelf with adjustable brackets



# Deluxe Workbench Cabinets



**F89618BS**  
48" 3-6-6-9" All-Drawer Configuration, shown in Black/Silver



**F89616RB**  
48" 3-3-6-6-6"/Door Configuration, shown in Black/Red

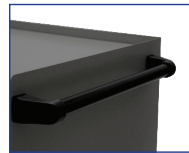

Removable handle

### Available Colors



Black / Red    Black / Silver

## 48" Models

Model		Description	Drawer Heights			Weight (lbs)
Black/Red	Black/Silver		3"	6"	9"	
F89623RB	F89623BS	2 doors & 2 adjustable shelves	-	-	-	160
F89613RB	F89613BS	1 RH door & 4 drawers (3,6,6,9)	1	2	1	191
F89616RB	F89616BS	1 RH door & 5 drawers (3,3,6,6,6)	2	3	-	198
F89618RB	F89618BS	2 full sets of 4 drawers (3,6,6,9)	2	4	2	222
F89621RB	F89621BS	2 full sets of 5 drawers (3,3,6,6,6)	4	6	-	236

- Dimensions: 48" W x 21"D x 36"H
- Flush front drawers and doors
- Single point locking mechanism
- Removable push handle that can be mounted on either left or right side
- Textured powder coat finish, available in 2 color combinations
- Rolls smoothly on (4) 6" locking swivel casters
- Drawers offer 100 lbs load capacity and heavy duty ball bearing glides
- Door compartment includes one shelf with adjustable brackets

## Accessories

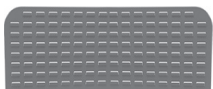

LOUVER BACK PANEL

F89370BK

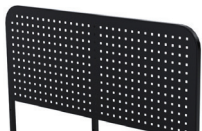

PEGBOARD BACK PANEL

F89391BK



BUTCHER BLOCK TOP

F89601



NON-SKID RUBBER TOP

F89599



RUBBER MAT DRAWER INSERT

F89597

### COMPARTMENT DRAWER DIVIDERS

	F80132A5	16 compartment
	F80131A4	12 compartment
	F80130A3	8 compartment

### HANGING & STACKABLE BINS

	<b>XS</b> 5½" L x 4⅞" W x 3" H <b>Z80419A7</b> (Case of 24)
	<b>S</b> 7½" L x 4⅞" W x 3" H <b>Z80421A5</b> (Case of 24)
	<b>M</b> 11" L x 5½" W x 5" H <b>Z80422A4</b> (Case of 12)
	<b>L</b> 14¾" L x 8¼" W x 7" H <b>Z80424A2</b> (Case of 12)
	<b>XL</b> 14¾" L x 16½" W x 7" H <b>Z80426A0</b> (Case of 6)



## Post Protectors

Valley Craft's Post Protectors are designed to protect almost any industrial racking system on the market. Heavy duty 1/4" steel makes each Post Protector virtually indestructible. It will add years to the life of your existing racks by protecting the posts from accidental denting and marring. Includes hardware for installation. Measures 6"W x 7 1/4"D. Available in Safety Yellow color.

Model	Height	Product Weight
F85061A2	12"	8 lbs
F85060A3	18"	10 lbs
F85062A1	24"	12 lbs



**F85061A2**  
12" Post Protector



## Work Tables - Adjustable Height

Heavy Duty Adjustable Height Work Tables are manufactured with ergonomically-designed legs that adjust from 28" to 42" high and fold down for easy transport and storage. Thick formed tops have welded channels underneath - available in either steel or wood top. Table and legs are constructed of 14-gauge steel. Includes two brace supports and hardware. Ships unassembled. 2,000-lbs load capacity. Center leg support and stringer shelf option are available for 120-inch model only.

Description	Steel Top Model #		Wood Top Model #	
	Part Number	Product Weight	Part Number	Product Weight
28"W x 84"L Folding Work Table	F87857A3	147 lbs	F87866A4	164 lbs
34"W x 84"L Folding Work Table	F87858A2	159 lbs	F87867A3	179 lbs
48"W x 84"L Folding Work Table	F87859A1	209 lbs	F87868A2	239 lbs
28"W x 96"L Folding Work Table	F87860A0	184 lbs	F87869A1	169 lbs
34"W x 96"L Folding Work Table	F87861A9	224 lbs	F87870A0	208 lbs
48"W x 96"L Folding Work Table	F87862A8	226 lbs	F87871A9	258 lbs
28"W x 120"L Folding Work Table	F87863A7	266 lbs	F87872A8	222 lbs
34"W x 120"L Folding Work Table	F87864A6	291 lbs	F87873A7	259 lbs
48"W x 120"L Folding Work Table	F87865A5	362 lbs	F87874A6	406 lbs
Optional Stringer Shelf for 120" Models	F86295A4		123 lbs	

**F87862A8**  
48 x 96" Steel Top



**F87872A8**  
28 x 120" Wood Top



**F87863A7**  
28 x 120" Steel Top

**F86295A4**  
Stringer Shelf



**F87864A6**  
34 x 120" Steel Top



# Heavy Duty Shelving



**F85295A0**  
72" Corner Post shown with **F85321A8** - 24x60 Shelf Pak



**F85295A0**  
72" Corner Post shown with **F85316A4** - 24x60x72 Panel Pak and **F85321A8** - 24x60 Shelf Pak

Heavy Duty Shelving was designed to stand up to years of heavy use and built with heavy material storage in mind. Customized shelving for longevity and durability.

- 60" or 72" heights, and widths of 36", 48" and 60"
- 12-ga., reinforced flanged, steel shelves
- Hardware kit available for connecting multiple shelving units together, end to end
- 2500 lbs. capacity per shelf
- Light Gray powder coat finish
- Corner Post Paks include 4 posts - enough to assemble one shelving unit
- Panel Paks include 20-ga. steel sides and back panel to enclose your shelving unit
- Shelf Paks consist of 5 shelves, cross braces, end braces, and hardware for assembly
- 10-ga., 2" x 2" galvanized sheet metal corner posts
- Ships unassembled

## ORDERING INSTRUCTIONS FOR HEAVY DUTY SHELVING

1. Select the **Corner Post Pak** for your shelving unit (Pak contains 4 posts). Two options are available, either 60" or 72" in height.

Model	Description
F85294A1	60" H Corner Post Pak
F85295A0	72" H Corner Post Pak

2. Select the **Shelf Pak** that best fits your needs (Pak includes 5 shelves). Shelf options are available in varying depths (18" or 24") and widths (36", 48", or 60"). Shelf Paks include 5 shelves, cross braces, end braces, and the necessary hardware to assemble your shelving unit. The use of the cross braces and end braces provided Pak ensure stability and maximum capacity of your shelving unit. If you require additional shelves, feel free to select **Individual Shelf** options that will fit in your shelving unit.

F85321A8	60" W x 24" D Shelf Pak
F85322A7	48" W x 24" D Shelf Pak
F85323A6	36" W x 24" D Shelf Pak
F85324A5	36" W x 18" D Shelf Pak

F85317A3	60" W x 24" D Individual Shelf
F85318A2	48" W x 24" D Individual Shelf
F85319A1	36" W x 24" D Individual Shelf
F85320A0	36" W x 18" D Individual Shelf

3. If you want to enclose your shelving unit (sides and back), please select a **Panel Pak** that coordinates with the depth, width, and height of your previous selections. Panel Paks can be easily attached with the hardware that is included in your Shelf Pak (already selected).

F85296A9	36" W x 18" D x 60" H Panel Pak
F85297A8	36" W x 24" D x 60" H Panel Pak
F85298A7	48" W x 24" D x 60" H Panel Pak
F85299A6	60" W x 24" D x 60" H Panel Pak
F85313A7	36" W x 18" D x 72" H Panel Pak
F85314A6	36" W x 24" D x 72" H Panel Pak
F85315A5	48" W x 24" D x 72" H Panel Pak
F85316A4	60" W x 24" D x 72" H Panel Pak

4. The **Hardware Kit** offered is only needed if you wish to connect multiple shelving units, end to end. For each additional shelving unit, please order that same quantity of hardware kits.

F85312A8	Hardware Kit
----------	--------------

## Bin and Shelf Cabinets

High capacity cabinets are available in a variety of sizes and multiple bin and shelving options to customize our cabinets to meet your storage needs. All cabinets feature a 3-point locking handle.

### Bin Sizes

X Small (**XS**): 4 $\frac{1}{8}$ " W x 5 $\frac{1}{2}$ " L x 3" H (8 lbs capacity)  
 Small (**S**): 4 $\frac{1}{8}$ " W x 7 $\frac{1}{2}$ " L x 3" H (10 lbs capacity)  
 Medium (**M**): 5 $\frac{1}{2}$ " W x 11" L x 5" H (30 lbs capacity)  
 Large (**L**): 8 $\frac{1}{4}$ " W x 14 $\frac{3}{4}$ " L x 7" H (60 lbs capacity)  
 X Large (**XL**): 16 $\frac{1}{2}$ " W x 14 $\frac{3}{4}$ " L x 7" H (75 lbs capacity)

## Extra Wide Storage Cabinets



F87954A6

Model	Door Style	Dimensions W x D x H	Bins	Shelving
F87955A5	Flush	60 x 24 x 84"	Bin Brackets Only	N/A
F87104A7	Flush	60 x 24 x 84"	Bin Brackets Only	(3) 60 x 18" shelves
F87953A7	Flush	60 x 24 x 84"	227 Total (80) XS; (90) S; (30) M; (18) L; (9) XL	N/A
F87954A6	Flush	60 x 24 x 84"	185 Total (80) XS; (90) S; (6) L; (9) XL	(3) 60 x 18" shelves
F85870A5	Flush	72 x 24 x 84"	Bin Brackets Only	N/A
F85869A6	Flush	72 x 24 x 84"	212 Total (96) XS; (96) S; (8) L; (12) XL	(3) 72 x 18" shelves
F85868A7	Flush	72 x 24 x 84"	264 Total (96) XS; (96) S; (36) M; (24) L; (12) XL	N/A



F88127A2

## Utility Drawer Cabinets

Model	Door Style	Dimensions W x D x H	Bins	Shelving
F88126A3	Flush	36 x 24 x 72"	Louvered Panels Only (full doors & upper cabinet louvers)	(2) 36 x 18" shelves (12) 18 x 4" door shelves
F88124A5	Flush	36 x 24 x 72"	52 total (36) XS, (12) M, (4) L (full doors & upper cab louvers)	(2) 36 x 18" shelves (12) 18 x 4" door shelves
F88130A9	Deep	36 x 24 x 72"	58 total (36) XS, (18) M, (4) L (upper doors & upper cab louvers)	(2) 36 x 18" shelves (12) 18 x 4" door shelves
F88122A7	Flush	48 x 24 x 78"	69 total (56) XS, (11) L, (2) XL (full doors & upper cab louvers)	(2) 48 x 18" shelves (12) 23 x 4" door shelves
F88128A1	Deep	48 x 24 x 72"	72 total: (56) XS, (8) M, (6) L, (2) XL (upper doors & upper cab louvers)	(2) 48 x 18" shelves (12) 23 x 4" door shelves



F87841A5

## Flush Door Bin & Shelf Cabinets

Model	Door Style	Dimensions W x D x H	Bins	Shelving
F87200A0	Flush	48 x 24 x 78"	No Bin Brackets	(3) 48 x 22" shelves
F87198A4	Flush	48 x 24 x 78"	Bin Bracket Only	(2) 48 x 18" shelves (6) 18 x 4" door shelves
F87451A6	Flush	48 x 24 x 78"	128 Total (128) XS	(4) 48 x 18" shelves
F87841A5	Flush	48 x 24 x 78"	137 Total (64) XS; (64) S; (3) L; (6) XL red, white, blue	(3) 48 x 18" shelves
F87842A4	Flush	48 x 24 x 78"	137 Total (64) XS; (64) S; (3) L; (6) XL all yellow	(3) 48 x 18" shelves

### Extra Shelving

**F87854A2**

36 x 18" shelf  
800-lb. capacity

**F87855A1**

36 x 22" shelf  
800-lb. capacity

**F87845A1**

48 x 18" shelf  
400-lb. capacity

**F87856A0**

48 x 22" shelf  
400-lb. capacity

**F87956A4**

60 x 18" shelf  
500-lb. capacity

**F85871A4**

72 x 18" shelf  
500-lb. capacity

**F87837A1**

18 x 4" door shelf  
25-lb. capacity  
(Hang on louver panels)

**F87993A7**

12 x 4" door shelf  
25-lb. capacity  
(Hang on louver panels)



Professional Grade Quality....Built to Last....Made in the U.S.A.

## Flush Door Bin Cabinets

Model	Door Style	Dimensions W x D x H	Included Bins	Shelving
F87844A2	Flush	48 x 24 x 78"	Louvered Panels Only	N/A
F87843A3	Flush	48 x 24 x 78"	171 Total (64) XS, (64) S, (24) M, (13) L, (6) XL	N/A



F87843A3

## Deep Door Bin & Shelf Cabinets

Model	Door Style	Dimensions W x D x H	Included Bins	Shelving
F87452A5	Deep	36 x 24 x 72"	N/A	(4) 36 x 18" shelves (12) 18 x 4" door shelves
F87308A1	Deep	36 x 24 x 72"	Louvered Panels in Doors Only	(4) 36 x 18" shelves
F87309A0	Deep	36 x 24 x 72"	Full Louvered Panels in Doors & Lower Half of Cab	(3) 36 x 18" shelves
F87307A2	Deep	36 x 24 x 72"	96 Total: (96) XS Full Louvered Panels in Doors Only	(4) 36 x 18" shelves
F87972A8	Deep	48 x 24 x 84"	N/A	(4) 48 x 18" shelves (12) 23 x 4" door shelves
F87971A9	Deep	48 x 24 x 84"	84 Total: (64) S, (20) L Louver Panels Lower Half of Cab and Lower Half of Doors	(2) 48 x 18" shelves (6) 23 x 4" door shelves
F87970A0	Deep	48 x 24 x 84"	144 Total: (144) XS Full Louvered Panels in Doors Only	(4) 48 x 18" shelves



F87969A1

## Deep Door Bin Cabinets

Model	Door Style	Dimensions W x D x H	Included Bins	Shelving
F87199A3	Deep	36 x 24 x 72"	Louvered Panels Only	N/A
F87969A1	Deep	48 x 24 x 84"	192 Total (72) XS, (72) S, (24) M, (18) L, (6) XL	N/A
F87992A8	Deep	48 x 24 x 84"	Louvered Panels Only	N/A



F87971A9

## Multi-Use Utility Cabinets

Model	Door Style	Dimensions W x D x H	Features
F85881A4	Flush	48 x 24 x 78"	Pegboard Panels on doors (4) 48 x 18" shelves (64) S Bins
F85880A5	Flush	48 x 24 x 78"	Pegboard panels top 1/2 of doors & top inner Louvered panels on lower doors (2) 48 x 18" shelves



F85880A5

## Hi-Vis Bin Cabinets

Model	Door Style	Dimensions W x D x H	Included Bins
F86227A1	Flush	36 x 20 x 78"	36 Total (36) L: 8 1/4"W x 7"H x 14 3/4"L
F86228A0	Flush	36 x 20 x 78"	18 Total (18) XL: 16 1/2"W x 7"H x 14 3/4"L



F86228A0

### Extra Shelving

- |   |   |   |   |   |   |   |   |
|---|---|---|---|---|---|---|---|
| <b>F87854A2</b><br>36 x 18" shelf<br>800-lb. capacity | <b>F87855A1</b><br>36 x 22" shelf<br>800-lb. capacity | <b>F87845A1</b><br>48 x 18" shelf<br>400-lb. capacity | <b>F87856A0</b><br>48 x 22" shelf<br>400-lb. capacity | <b>F87837A1</b><br>18 x 4" door shelf<br>25-lb. capacity<br>(hang on louvers) | <b>F87993A7</b><br>12 x 4" door shelf<br>25-lb. capacity<br>(hang on louvers) | <b>F87103A8</b><br>18"W x 4"D door shelf<br>25-lb. capacity bolt-on<br>for deep doors | <b>F87997A9</b><br>23"W x 4"D door shelf<br>25-lb. capacity bolt-on<br>for deep doors |
|---|---|---|---|---|---|---|---|

## Electronic Locking Cabinet



Valley Craft's Electronic Locking Cabinet adds extra strength and security to your storage system with the convenience of electronic lock management. The three-point locking system is anchored by a Digilock® electronic lock that includes a 1/2" deadbolt. Includes a programming bypass/master key. The all-welded steel cabinets feature shelves that handle up to 800 pounds each and are adjustable on 7 1/2" increments. Durable powder coat finish in Smoke Gray.



Digilock®

Model	Door Style	Dimensions W x D x H	Shelving	Shelf Capacity (lbs)	Product Weight (lbs)
F85875A0	Flush	36 x 24 x 72"	(3) 36"W x 22"D shelves	800	365
F85876A9	Flush	36 x 24 x 84"	(3) 36"W x 22"D shelves	800	385
F85877A8	Flush	48 x 24 x 72"	(3) 48"W x 22"D shelves	400	400
F85874A1	Flush	48 x 24 x 78"	(3) 48"W x 22"D shelves	400	450

## Heavy Duty Shelf Cabinets



Model F89783A4

Valley Craft's line of Heavy Duty Shelf Cabinets provide superior strength and security for storing a variety of industrial parts and supplies. The all-welded steel cabinets feature shelves that handle up to 1,000 pounds each and are adjustable on 7 1/2" increments. Channel reinforced doors in 84" tall cabinets and box formed shelves add extra strength and durability. Double doors swing open 180° for full access on full-length piano hinges. The 3-point locking handle with keys is zinc plated for long life. Cabinets come with four shelves in a variety of sizes to meet all your storage needs. Powder coat finish is Smoke Gray.

Model	Dimensions W x D x H	Shelf Dimensions W x D	Capacity (lbs)	Product Weight (lbs)
F89781A6	36 x 18 x 60"	36 x 16"	1,000	22
F89782A5	36 x 18 x 72"	36 x 16"	1,000	238
F89784A3	36 x 18 x 84"	36 x 16"	1,000	353
F89780A7	36 x 24 x 72"	36 x 22"	1,000	255
F89807A3	36 x 24 x 84"	36 x 22"	1,000	298
F89808A2	48 x 24 x 72"	48 x 22"	800	338
F89783A4	48 x 24 x 78"	48 x 22"	800	353
F89809A1	48 x 24 x 84"	48 x 22"	800	396

### Extra Shelving for Heavy Duty Shelf Cabinets

**F89778A9**  
36"W x 16"D shelf, 15 lbs  
1,000-lb. capacity

**F89775A3**  
36"W x 22"D shelf, 18 lbs  
1,000-lb. capacity

**F89772A6**  
48"W x 22"D shelf, 25 lbs  
800-lb. capacity



## Half Cabinets

Cabinet dimensions: 36" W x 24" D x 36" H

Model	Door Style	Included Bins	Shelving
F87459A8	Deep	74 Total (24) XS, (32) S, (12) M, (4) L, (2) XL	Full Louvers, No shelves, No full-width drawers



F88131A8

## 4-Drawer & 8-Drawer Kits

Drawer kits come in 4-drawer and 8-drawer units, and are only available as accessories for cabinets that have shelves. Drawers for 36"-wide cabinets have 4½" H x 30½" W x 16½" D of usable inside space, and drawers for 48"-wide cabinets have 4½" H x 42½" W x 16½" D of usable inside space.



F88137A3

Model	Description	Product Weight (lbs)
F88135A4	8-Drawer Kit for 36" Cab w/22" deep shelves	221
F88136A4	4-Drawer Kit for 48" Cab w/18" deep shelves	143
F88137A3	4-Drawer Kit for 48" Cab w/22" deep shelves	145
F88138A2	8-Drawer Kit for 48" Cab w/18" deep shelves	250

## 12 Gauge Heavy Duty Cabinets



F89165VCGY

Model	Dimensions W x D x H	Overall Height	Shelves Included	Shelf Capacity (lbs)	Included Bins	Full Louvered Doors	Product Weight (lbs)
F89164VCGY	36" x 24" x 72"	78"	4 - 36"W x 22"D	1900	-	No	478
F89162VCGY	36" x 24" x 72"	78"	4 - 36"W x 18"D	1900	32-XS, 32-S	Yes	512
F89165VCGY	48" x 24" x 72"	78"	4 - 48"W x 22"D	1500	-	No	582
F89160VCGY	48" x 24" x 72"	78"	4 - 48"W x 18"D	1500	64-XS, 64-S	Yes	629
F89163VCGY	60" x 24" x 72"	78"	4 - 60"W x 22"D	1650	-	No	728
F89161VCGY	60" x 24" x 72"	78"	4 - 60"W x 18"D	1650	64-XS, 64-S	Yes	802

- 12-gauge steel and all-welded construction
- Adjustable shelves on 3-inch increments provide individual shelf capacity of 1,500, 1,650, and 1,900 pounds, depending on model
- 3-point locking mechanism with padlockable handle
- Heavy duty door design features louvered panels and durable pin hinges for added door rigidity
- 7-gauge steel legs with hole to anchor cabinet to floor
- Cabinet can be transported with fork lift or pallet jack
- Durable powder coat finish in Smoke Gray



# Valley Craft Industries, Inc. Standard Terms and Conditions

## Prices are Subject to Change without Notice.

### Payment Terms:

For Customers with approved credit, payment terms on standard or contracted products are net 30 days from date of invoice, and any unpaid balance shall be subject to a late charge of 1.5 percent per month thereafter. Minimum order policy: net \$25.

See 'Custom Products' section below for terms specific to non-standard products.

### Returns:

Valley Craft ships only first-quality merchandise after thorough inspection in strict compliance with customer orders. There is a 30-day return policy on all standard parts and products. All returns must have prior written factory approval. Returns made otherwise will not be accepted at the receiving dock and may result in customer liability for carrier storage charges. Authorized return merchandise will be subject to a 25 percent restocking charge plus applicable freight charges. Return authorization will contain instructions regarding disposition and shipping address to be used for return merchandise.

### Custom Products (per quote specifications):

Products especially made to meet customer specifications are not returnable. An order acknowledgement and approval drawing will be provided on all custom orders. Be sure to check our acknowledgement of order and approval drawing against your requirements and report any discrepancies immediately. Valley Craft will not be responsible for incorrectly manufactured custom products that meet customer approved order acknowledgement and approval drawing specifications.

A down payment of 50% will be due within 10 days of order receipt. The remaining 50% is due net 30 days from product ship date. If down payment is not received within 10 days, work will be paused until payment is received. If order is cancelled by customer, customer is responsible for costs incurred up to the point of cancellation.

Shipments will be invoiced at prices effective upon receipt of order, unless prior arrangements have been made for shipment beyond normal lead time.

### Freight:

Shipments are made FOB origin unless otherwise quoted. Merchandise is shipped either FOB origin freight collect, or FOB origin freight prepaid and added to customer invoice.

### Freight Claims:

It is the receiving party's responsibility to make the proper notations on freight bills at the time of receipt of "short shipments" or damaged merchandise. It is also the receiving party's responsibility to initiate all claims with delivering carriers, and follow up on such claims until a satisfactory settlement is made with said carrier. Valley Craft Industries, Inc., is not responsible for short shipments due to loss by the carrier and/or damage in transit.

### Warranty & Limitation of Liability:

Valley Craft products are warranted for a period of one (1) year from date of shipment from Valley Craft's plant to be free from defects in material and workmanship under correct use, normal operating conditions and proper application. However, parts of other than Valley Craft manufacture are subject ONLY to the original manufacturer's warranty. Valley Craft's obligation under the warranty shall be limited to the repair or exchange, at Valley Craft's option, FOB Valley Craft's factory, of any Valley Craft product or part which proves to be defective as provided herein. Valley Craft reserves the right to either inspect the product at Buyer's location, or require it to be returned freight prepaid to the factory for inspection. The warranty contained herein does not extend to goods damaged, or subject to accident, abuse or misuse after shipment from Valley Craft's factory, nor to goods altered or repaired by anyone other than an authorized Valley Craft representative.

Buyer or user shall not alter, modify or use a Valley Craft product for anything other than its intended function. Valley Craft shall not in any way be responsible for the consequences of any such alteration, modification or misuse.

VALLEY CRAFT MAKES NO EXPRESS WARRANTIES OTHER THAN THOSE WHICH ARE SPECIFICALLY DESCRIBED HEREIN. Any description of the goods sold hereunder, including any references to Buyer's specifications and any descriptions in catalogs, circulars and other written material published by Valley Craft, is for the sole purpose of identifying such goods and shall not create an express warranty that the goods shall conform to such descriptions. THIS WARRANTY IS EXPRESSLY IN LIEU OF ALL OTHER WARRANTIES, EXPRESS OR IMPLIED. THERE ARE NO IMPLIED WARRANTIES OF MERCHANTABILITY OR FITNESS FOR A PARTICULAR PURPOSE. THIS WARRANTY STATES VALLEY CRAFT'S ENTIRE AND EXCLUSIVE LIABILITY, AND BUYER'S EXCLUSIVE REMEDY FOR ANY CLAIM FOR DAMAGES IN CONNECTION WITH THE SALE OR FURNISHINGS OF VALLEY CRAFT PRODUCTS, THEIR DESIGN, SUITABILITY FOR USE, INSTALLATION OR OPERATION OR FOR ANY CLAIMED DEFECTS THEREIN. VALLEY CRAFT WILL IN NO EVENT BE LIABLE FOR INCIDENTAL OR CONSEQUENTIAL DAMAGES WHATSOEVER, NOT FOR ANY SUM IN EXCESS OF THE PRICE RECEIVED FOR THE GOODS FOR WHICH LIABILITY IS CLAIMED.



Offering Custom Engineered Solutions



Parts Staging



Assembly Plant Logistics



Mobile Workcenter

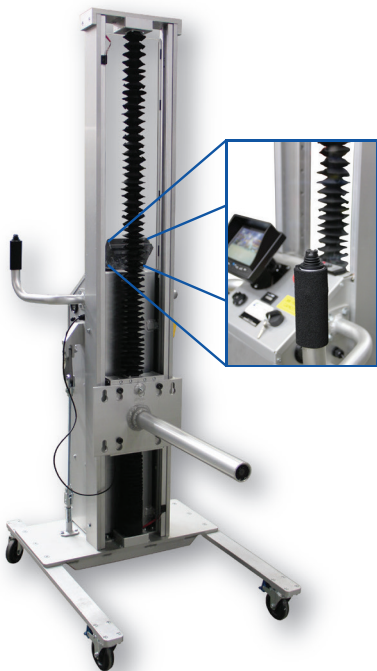

Roll Handler



Wide Reach Lift



Parts Transport



Mother/Daughter Cart